

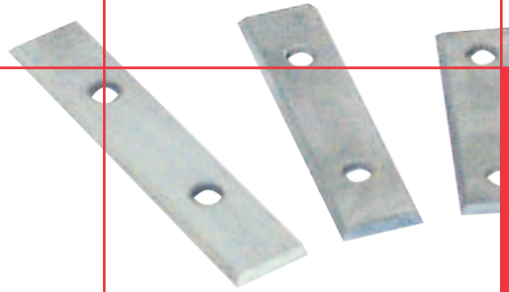

**BUP**  
UTENSILI

Knives - Spare parts

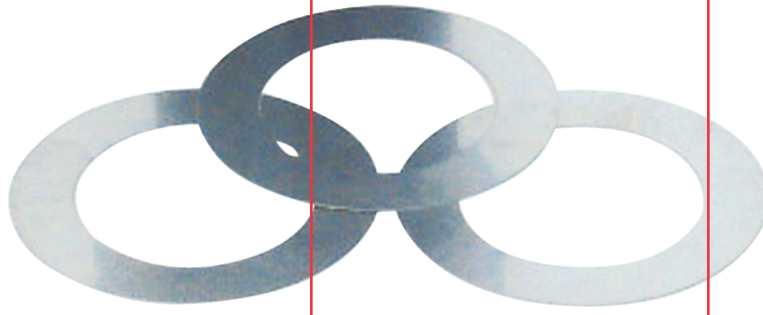
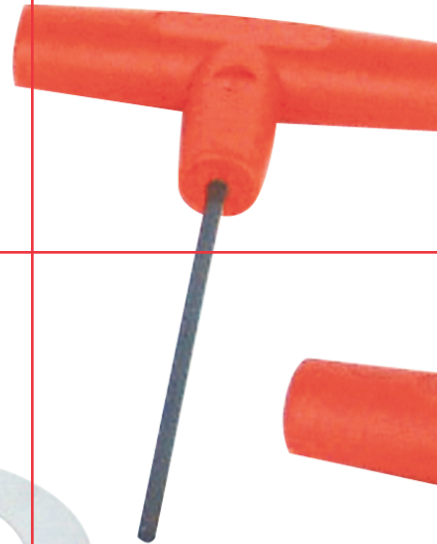

A/07

[www.buputensili.it](http://www.buputensili.it)

88

8



**Coltelli, accessori  
e ricambi**

***Knives, and  
spare parts***

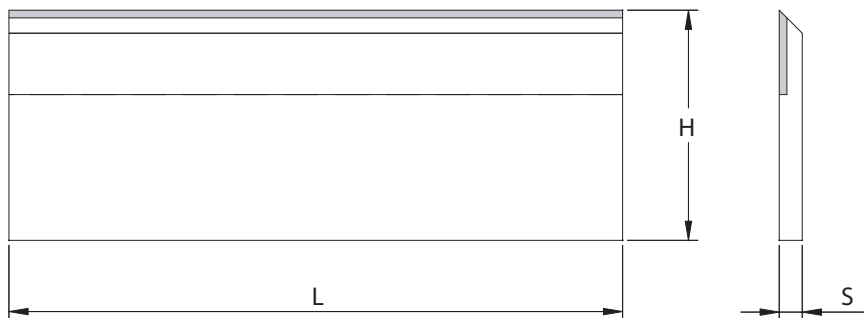
**8005****COLTELLI PER PIALLA IN HW  
CARBIDE PLANING KNIVES**

<b>Codice</b> <i>Code</i>	<b>L</b> <i>L</i>	<b>H</b> <i>H</i>	<b>S</b> <i>S</i>	<b>Cod. Prezzo</b> <i>Price Code</i>	<b>Codice</b> <i>Code</i>	<b>L</b> <i>L</i>	<b>H</b> <i>H</i>	<b>S</b> <i>S</i>	<b>Cod. Prezzo</b> <i>Price Code</i>
8005.080.030	80	30	3	C05	8005.080.035	80	35	3	C05
8005.100.030	100	30	3	L05	8005.100.035	100	35	3	L05
8005.120.030	120	30	3	L06	8005.120.035	120	35	3	L06
8005.130.030	130	30	3	C07	8005.130.035	130	35	3	C07
8005.140.030	140	30	3	L07	8005.140.035	140	35	3	L07
8005.150.030	150	30	3	C08	8005.150.035	150	35	3	C08
8005.160.030	160	30	3	L08	8005.160.035	160	35	3	L08
8005.180.030	180	30	3	H09	8005.180.035	180	35	3	H09
8005.200.030	200	30	3	H10	8005.200.035	200	35	3	H10
8005.220.030	220	30	3	H11	8005.220.035	220	35	3	H11
8005.230.030	230	30	3	B12	8005.230.035	230	35	3	B12
8005.250.030	250	30	3	B13	8005.250.035	250	35	3	B13
8005.300.030	300	30	3	F14	8005.300.035	300	35	3	F14
8005.310.030	310	30	3	G14	8005.310.035	310	35	3	G14
8005.350.030	350	30	3	D15	8005.350.035	350	35	3	D15
8005.400.030	400	30	3	B16	8005.400.035	400	35	3	B16
8005.410.030	410	30	3	D16	8005.410.035	410	35	3	D16
8005.430.030	430	30	3	G16	8005.430.035	430	35	3	G16
8005.450.030	450	30	3	M16	8005.450.035	450	35	3	M16
8005.500.030	500	30	3	H17	8005.500.035	500	35	3	H17
8005.510.030	510	30	3	A18	8005.510.035	510	35	3	A18
8005.530.030	530	30	3	C18	8005.530.035	530	35	3	C18
8005.600.030	600	30	3	E19	8005.600.035	600	35	3	E19
8005.610.030	610	30	3	F19	8005.610.035	610	35	3	F19
8005.630.030	630	30	3	H19	8005.630.035	630	35	3	H19
8005.640.030	640	30	3	M19	8005.640.035	640	35	3	M19
8005.700.030	700	30	3	E20	8005.700.035	700	35	3	E20
8005.710.030	710	30	3	F20	8005.710.035	710	35	3	F20
8005.730.030	730	30	3	H20	8005.730.035	730	35	3	H20
8005.800.030	800	30	3	A21	8005.800.035	800	35	3	A21
8005.810.030	810	30	3	B21	8005.810.035	810	35	3	B21
8005.860.030	860	30	3	D21	8005.860.035	860	35	3	D21

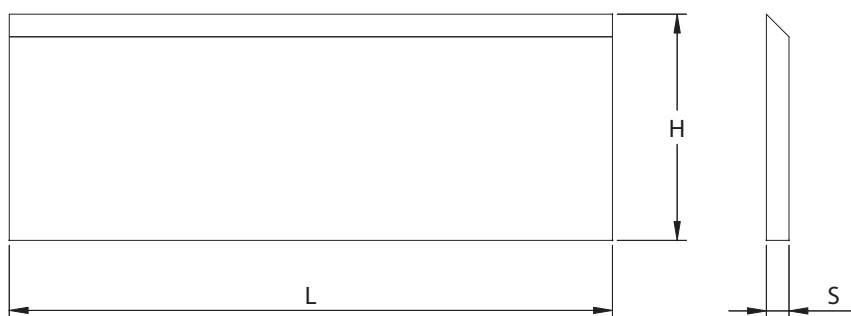

<b>Codice</b> <i>Code</i>	<b>L</b> <i>L</i>	<b>H</b> <i>H</i>	<b>S</b> <i>S</i>	<b>Cod. Prezzo</b> <i>Price Code</i>	<b>Codice</b> <i>Code</i>	<b>L</b> <i>L</i>	<b>H</b> <i>H</i>	<b>S</b> <i>S</i>	<b>Cod. Prezzo</b> <i>Price Code</i>
8010.080.030	80	30	3	CA05	8010.080.035	80	35	3	CA05
8010.100.030	100	30	3	MA05	8010.100.035	100	35	3	MA05
8010.120.030	120	30	3	CA07	8010.120.035	120	35	3	CA07
8010.130.030	130	30	3	LA07	8010.130.035	130	35	3	LA07
8010.140.030	140	30	3	EA08	8010.140.035	140	35	3	EA08
8010.150.030	150	30	3	BA09	8010.150.035	150	35	3	BA09
8010.160.030	160	30	3	HA09	8010.160.035	160	35	3	HA09
8010.180.030	180	30	3	MA09	8010.180.035	180	35	3	MA09
8010.200.030	200	30	3	B03	8010.200.035	200	35	3	B03
8010.220.030	220	30	3	G03	8010.220.035	220	35	3	G03
8010.230.030	230	30	3	H03	8010.230.035	230	35	3	H03
8010.250.030	250	30	3	A04	8010.250.035	250	35	3	A04
8010.300.030	300	30	3	G04	8010.300.035	300	35	3	G04
8010.310.030	310	30	3	H04	8010.310.035	310	35	3	H04
8010.350.030	350	30	3	C05	8010.350.035	350	35	3	C05
8010.400.030	400	30	3	L05	8010.400.035	400	35	3	L05
8010.410.030	410	30	3	M05	8010.410.035	410	35	3	M05
8010.430.030	430	30	3	B06	8010.430.035	430	35	3	B06
8010.450.030	450	30	3	E06	8010.450.035	450	35	3	E06
8010.500.030	500	30	3	A07	8010.500.035	500	35	3	A07
8010.510.030	510	30	3	C07	8010.510.035	510	35	3	C07
8010.530.030	530	30	3	E07	8010.530.035	530	35	3	E07
8010.600.030	600	30	3	C08	8010.600.035	600	35	3	C08
8010.610.030	610	30	3	E08	8010.610.035	610	35	3	E08
8010.630.030	630	30	3	G08	8010.630.035	630	35	3	G08
8010.640.030	640	30	3	H08	8010.640.035	640	35	3	H08
8010.700.030	700	30	3	F09	8010.700.035	700	35	3	F09
8010.710.030	710	30	3	G09	8010.710.035	710	35	3	G09
8010.730.030	730	30	3	L09	8010.730.035	730	35	3	L09
8010.800.030	800	30	3	H10	8010.800.035	800	35	3	H10
8010.810.030	810	30	3	L10	8010.810.035	810	35	3	L10
8010.860.030	860	30	3	E11	8010.860.035	860	35	3	E11

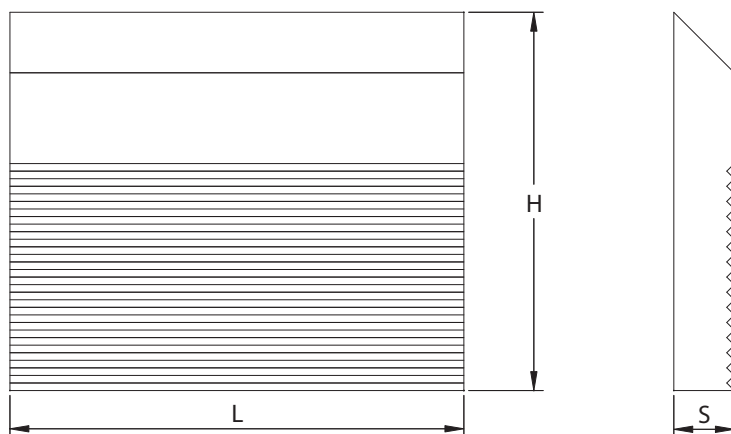
**8018****COLTELLI RIGATI HS  
HS SERRATED BACK KNIVES**

**Coltello con affilatura aumento 15%**  
**Straight grinded knife increase 15%**

**HS - H = 50 mm**

<b>Codice</b> <i>Code</i>	<b>L</b> <i>L</i>	<b>H</b> <i>H</i>	<b>S</b> <i>S</i>	<b>Codice Prezzo</b> <i>Price Code</i>
8018.040.050	40	50	8	L03
8018.050.050	50	50	8	E04
8018.060.050	60	50	8	B05
8018.080.050	80	50	8	F05
8018.100.050	100	50	8	H06
8018.120.050	120	50	8	M07
8018.130.050	130	50	8	E08
8018.150.050	150	50	8	G09
8018.180.050	180	50	8	E11
8018.230.050	230	50	8	A14
8018.650.050	650	50	8	F20

**HS - H = 60 mm**

8018.040.060	40	60	8	B04
8018.050.060	50	60	8	H04
8018.060.060	60	60	8	D05
8018.080.060	80	60	8	B06
8018.100.060	100	60	8	E07
8018.120.060	120	60	8	G08
8018.130.060	130	60	8	D09
8018.150.060	150	60	8	G10
8018.180.060	180	60	8	F12
8018.230.060	230	60	8	F14
8018.650.060	650	60	8	M20

**HS - H = 70 mm**

8018.040.070	40	70	8	E04
8018.050.070	50	70	8	M04
8018.060.070	60	70	8	H05
8018.080.070	80	70	8	G06
8018.100.070	100	70	8	A08
8018.120.070	120	70	8	E09
8018.130.070	130	70	8	B10
8018.150.070	150	70	8	F11
8018.180.070	180	70	8	H13
8018.230.070	230	70	8	A15
8018.650.070	650	70	8	B21

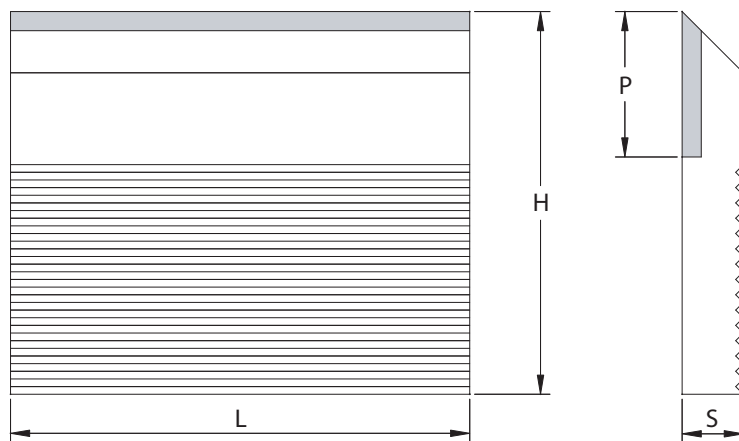
**8019****COLTELLI RIGATI HW  
HW SERRATED BACK KNIVES**

**Coltello con affilatura aumento 15%**  
**Straight grinded knife increase 15%**

**HW - H = 50 mm**

<b>Codice</b> <i>Code</i>	<b>L</b> <i>L</i>	<b>H</b> <i>H</i>	<b>S</b> <i>S</i>	<b>P</b> <i>P</i>	<b>Codice Prezzo</b> <i>Price Code</i>
8019.040.050	40	50	8	20	M08
8019.050.050	50	50	8	20	B10
8019.060.050	60	50	8	20	M10
8019.080.050	80	50	8	20	A14
8019.100.050	100	50	8	20	C15
8019.120.050	120	50	8	20	B16
8019.130.050	130	50	8	20	G16
8019.150.050	150	50	8	20	D17
8019.180.050	180	50	8	20	L18
8019.230.050	230	50	8	20	H20
8019.650.050	650	50	8	20	E30

**HW - H = 60 mm**

8019.040.060	40	60	8	25	M10
8019.050.060	50	60	8	25	B12
8019.060.060	60	60	8	25	E13
8019.080.060	80	60	8	25	B15
8019.100.060	100	60	8	25	G16
8019.120.060	120	60	8	25	L17
8019.130.060	130	60	8	25	D18
8019.150.060	150	60	8	25	C19
8019.180.060	180	60	8	25	F20
8019.230.060	230	60	8	25	E21
8019.650.060	650	60	8	25	A31

**HW - H = 70 mm**

8019.040.070	40	70	8	30	L12
8019.050.070	50	70	8	30	B14
8019.060.070	60	70	8	30	G14
8019.080.070	80	70	8	30	C16
8019.100.070	100	70	8	30	A18
8019.120.070	120	70	8	30	E19
8019.130.070	130	70	8	30	M19
8019.150.070	150	70	8	30	F20
8019.180.070	180	70	8	30	C21
8019.230.070	230	70	8	30	M21
8019.650.070	650	70	8	30	D31

# 8020 - 8021

## COLTELLI A GETTARE IN HW INTEGRALE SOLID CARBIDE INDEXABLE KNIVES

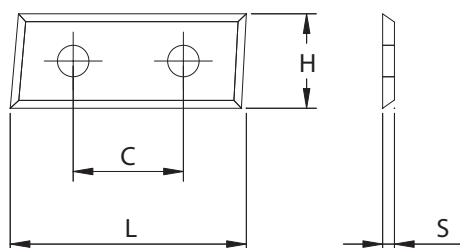

Ricambi per Articolo 2210  
Spare knives for Article 2210

Codice Dx Rh Code	Codice Sx Lh Code	L L	H H	S S	C C	Qualità Grade	Codice Prezzo Price Code
8020.300.012	8021.300.012	30	12	1,5	14	HC05	EA02
8020.301.012	8021.301.012	30	12	1,5	14	MG06	DA03
8020.302.012	8021.302.012	30	12	1,5	14	SMG02	BA04
8020.303.012	8021.303.012	30	12	1,5	14	UMG04	FA06

# 8025

## COLTELLI A GETTARE IN HW INTEGRALE SOLID CARBIDE INDEXABLE KNIVES

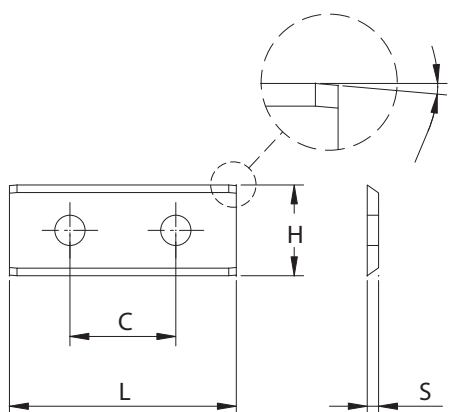

Ricambi per Articoli 2135 - 2140 - 2180 - 2185  
Spare knives for Article 2135 - 2140 - 2180 - 2185

Codice Code	L L	H H	S S	C C	Qualità Grade	Codice Prezzo Price Code
8025.200.012	20	12	1,5	-	HC05	LA03
8025.300.012	30	12	1,5	14	HC05	LA03
8025.500.012	50	12	1,5	26	HC05	CA04

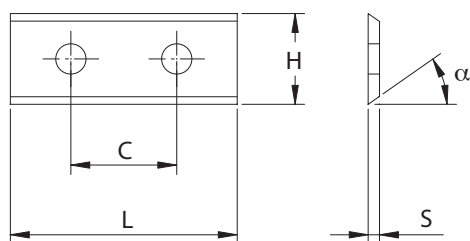
**MG06**

Qualità micrograno, per MDF e truciolare  
Micron grade quality, for MDF and chipboard

**SMG02**

Qualità submicrograno, per MDF e HDF  
Submicron grade quality, for MDF and HDF

**UMG04**

Qualità ultramicrograno, per HDF  
Ultra micron grade quality, for HDF

**Art. 8102 - MG06**

Codice Code	L L	H H	S S	C C	$\alpha^\circ$ $\alpha^\circ$	Qualità Grade	Codice Prezzo Price Code
8102.076.012	7,65	12	1,5	-	35°	MG06	HA01
8102.096.012	9,6	12	1,5	-	35°	MG06	GA02
8102.120.012	12	12	1,5	-	35°	MG06	BA02
8102.150.012	15	12	1,5	-	35°	MG06	CA02
8102.200.012	20	12	1,5	-	35°	MG06	CA02
8102.250.012	24,7	12	1,5	-	35°	MG06	LA03
8102.300.012	30	12	1,5	14	35°	MG06	FA02
8102.400.012	40	12	1,5	26	35°	MG06	LA02
8102.500.012	50	12	1,5	26	35°	MG06	DA03
8102.600.012	60	12	1,5	26	35°	MG06	FA05

**Art. 8103 - SMG02**

Codice Code	L L	H H	S S	C C	$\alpha^\circ$ $\alpha^\circ$	Qualità Grade	Codice Prezzo Price Code
8103.096.012	9,6	12	1,5	-	35°	SMG02	DA04
8103.120.012	12	12	1,5	-	35°	SMG02	CA02
8103.150.012	15	12	1,5	-	35°	SMG02	BA03
8103.200.012	20	12	1,5	-	35°	SMG02	MA02
8103.300.012	30	12	1,5	14	35°	SMG02	DA03
8103.400.012	40	12	1,5	26	35°	SMG02	LA04
8103.500.012	50	12	1,5	26	35°	SMG02	FA04
8103.600.012	60	12	1,5	26	35°	SMG02	HA08

**Art. 8104 - UMG04**

Codice Code	L L	H H	S S	C C	$\alpha^\circ$ $\alpha^\circ$	Qualità Grade	Codice Prezzo Price Code
8104.200.012	20	12	1,5	-	35°	UMG04	AA05
8104.300.012	30	12	1,5	14	35°	UMG04	GA05
8104.500.012	50	12	1,5	26	35°	UMG04	HA07

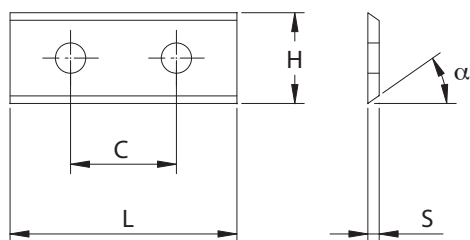
**HC05**

Qualità standard per impiego generale  
Standard quality, for general use

**MG18**

Qualità micrograno, per legni duri  
Micron grade quality, for hardwoods

**HE40**

Qualità speciale per legni teneri  
None cobalt grade for soft woods

**Art. 8105 - HC05**

Codice Code	L L	H H	S S	C C	$\alpha^\circ$ $\alpha^\circ$	Qualità Grade	Codice Prezzo Price Code
8105.076.012	7,65	12	1,5	-	35°	HC05	CA01
8105.096.012	9,6	12	1,5	-	35°	HC05	BA02
8105.105.012	10,5	10,5	1,5	-	35°	HC05	DA03
8105.120.012	12	12	1,5	-	35°	HC05	FA01
8105.150.012	15	12	1,5	-	35°	HC05	FA01
8105.200.012	20	12	1,5	-	35°	HC05	FA01
8105.250.012	24,7	12	1,5	-	35°	HC05	MA02
8105.300.012	30	12	1,5	14	35°	HC05	HA01
8105.400.012	40	12	1,5	26	35°	HC05	GA02
8105.500.012	50	12	1,5	26	35°	HC05	GA02
8105.600.012	60	12	1,5	26	35°	HC05	DA04
8105.800.012	80	13	2,2	60	35°	HC27	E04
8105.900.012	100	13	2,2	60	35°	HC27	E05
8105.920.012	120	13	2,2	60	35°	HC27	C06

**Art. 8106 - MG18**

8106.076.012	7,65	12	1,5	-	45°	MG18	FA02
8106.096.012	9,6	12	1,5	-	45°	MG18	EA04
8106.120.012	12	12	1,5	-	45°	MG18	GA02
8106.150.012	15	12	1,5	-	45°	MG18	GA02
8106.200.012	20	12	1,5	-	45°	MG18	GA02
8106.300.012	30	12	1,5	14	45°	MG18	DA02
8106.400.012	40	12	1,5	26	45°	MG18	GA04
8106.500.012	50	12	1,5	26	45°	MG18	LA03
8106.600.012	60	12	1,5	26	45°	MG18	CA06
8106.800.012	80	13	2,2	60	45°	MG18	G05

**Art. 8107 - HE40**

8107.096.012	9,6	12	1,5	-	45°	HE40	LA04
8107.120.012	12	12	1,5	-	45°	HE40	MA04
8107.150.012	15	12	1,5	-	45°	HE40	GA05
8107.200.012	20	12	1,5	-	45°	HE40	LA04
8107.300.012	30	12	1,5	14	45°	HE40	EA03
8107.400.012	40	12	1,5	26	45°	HE40	HA05
8107.500.012	50	12	1,5	26	45°	HE40	MA03
8107.600.012	60	12	1,5	26	45°	HE40	F03
8107.800.012	80	13	2,2	60	45°	HE40	L04

# 8110

## COLTELLI A GETTARE IN HW INTEGRALE SOLID CARBIDE INDEXABLE KNIVES

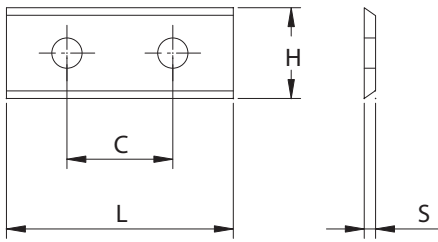

Ricambi per Articolo 5086  
Spare parts for Article 5086

Codice Code	L L	H H	S S	C C	Qualità Grade	Codice Prezzo Price Code
8110.150.009	15	9	1,5	-	HC05	DA03
8110.200.009	20	9	1,5	-	HC05	DA03
8110.300.009	30	9	1,5	14	HC05	DA03
8110.400.009	40	9	1,5	26	HC05	DA03
8110.500.009	50	9	1,5	26	HC05	FA03
8110.600.009	60	9	1,5	26	HC05	FA03

# 8115

## COLTELLI A GETTARE IN HW INTEGRALE SOLID CARBIDE INDEXABLE KNIVES

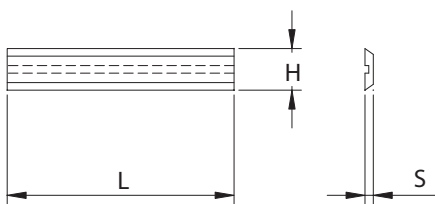

Codice Code	L L	H H	S S	Qualità Grade	Codice Prezzo Price Code
8115.200.055	20	5,5	1,1	HC05	DA01
8115.300.055	30	5,5	1,1	HC05	HA01
8115.400.055	40	5,5	1,1	HC05	DA01
8115.500.055	50	5,5	1,1	HC05	MA02
8115.600.055	60	5,5	1,1	HC05	MA03

# 8120

## COLTELLI A GETTARE IN HW INTEGRALE SOLID CARBIDE INDEXABLE KNIVES

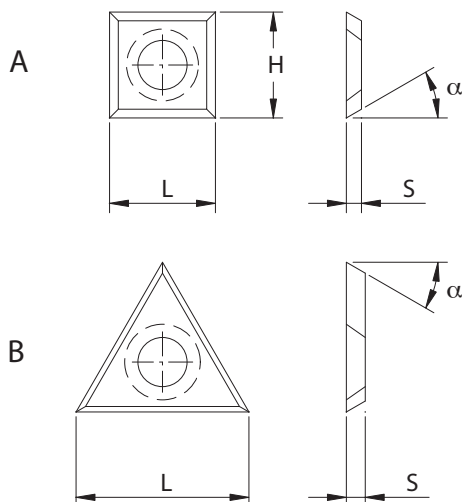

Codice Code	L L	H H	S S	$\alpha$ $\alpha$	Tipo Type	Qualità Grade	Codice Prezzo Price Code
8120.140.001	14	14	1,2	30°	A	HC35	CA02
8120.140.002	14	14	2	30°	A	HC35	LA01
8120.228.003	22		2	30°	B	MG18	AA03

# 8125

## COLTELLI A GETTARE IN HW INTEGRALE SOLID CARBIDE INDEXABLE KNIVES

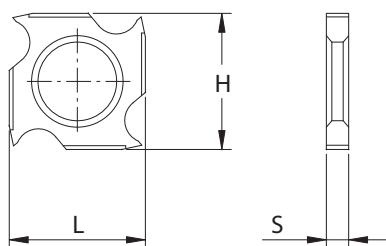

Ricambi per Articoli 2010 - 2020  
Spare parts for Articles 2010 - 2020

Codice Code	L L	H H	S S	Qualità Grade	Codice Prezzo Price Code
8125.180.019	18	18	1,95	HC20	BA05
8125.180.025	18	18	2,50	HC20	HA05
8125.180.029	18	18	2,95	HC20	AA07
8125.180.037	18	18	3,70	HC20	DA09
8125.180.040	18	18	4,00	HC20	HA09

# 8130

## INSERTI LEVASPIGOLI IN HW INTEGRALE SOLID CARBIDE ROUNDING/CHAMFERING KNIVES

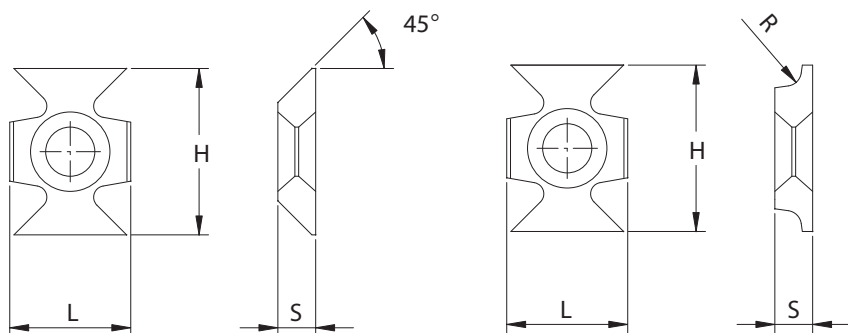

**HW** **MEC** Avanzamento meccanico  
Mechanical feed

Codice Code	L L	H H	S S	R R	$\alpha$ $\alpha$	Qualità Grade	Codice Prezzo Price Code
8130.220.045	16	22	5	-	45°	HC20	A03
8130.220.015	16	22	5	1,5	-	HC20	A03
8130.220.020	16	22	5	2	-	HC20	A03
8130.220.030	16	22	5	3	-	HC20	A03
8130.220.040	16	22	6	4	-	HC20	D03
8130.220.050	16	22	6	5	-	HC20	D03

# 8131 - 8132

## INSERTI LEVASPIGOLI IN HW INTEGRALE SOLID CARBIDE ROUNDING/CHAMFERING KNIVES

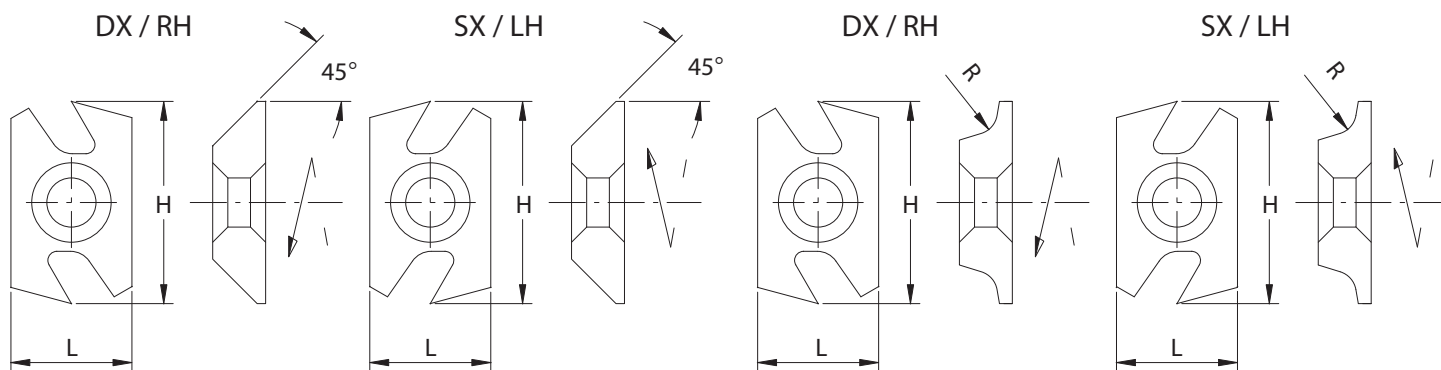

**HW** **MAN** Avanzamento manuale  
Manual feed

Codice Dx Rh code	Codice Sx Lh code	L L	H H	S S	R R	$\alpha$ $\alpha$	Qualità Grade	Codice Prezzo Price Code
8131.260.045	8132.260.045	16	26,74	7	-	45°	HC20	B05
8131.260.015	8132.260.015	16	26,74	7	1,5	-	HC20	B05
8131.260.020	8132.260.020	16	26,74	7	2	-	HC20	B05
8131.260.030	8132.260.030	16	26,74	7	3	-	HC20	B05
8131.260.050	8132.260.050	16	26,74	7	5	-	HC20	B05

# 8140 - 8141

## INSERTI PER CANALI IN HW INTEGRALE SOLID CARBIDE GROOVING INSERTS

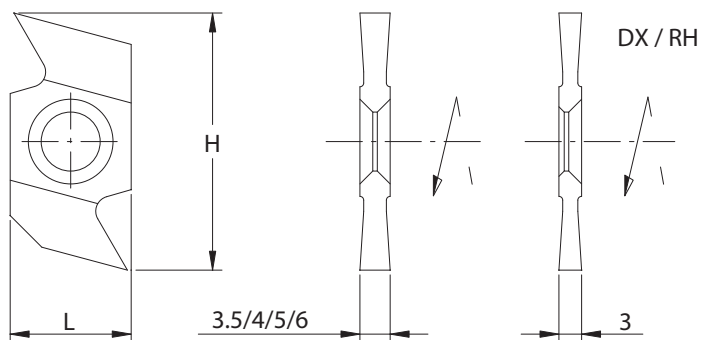

**HW** **MEC** Avanzamento meccanico  
Mechanical feed

Codice Dx Rh code	Codice Sx Lh code	L L	H H	S S	Codice Prezzo Price Code
8140.030.000	8141.030.000	16	34	3	L03
8140.035.000		16	34	3,5	M03
8140.040.000		16	34	4	M03
8140.050.000		16	34	5	A04
8140.060.000		16	34	6	C04

# 8142

## INSERTI PER CANALI IN HW INTEGRALE SOLID CARBIDE GROOVING INSERTS

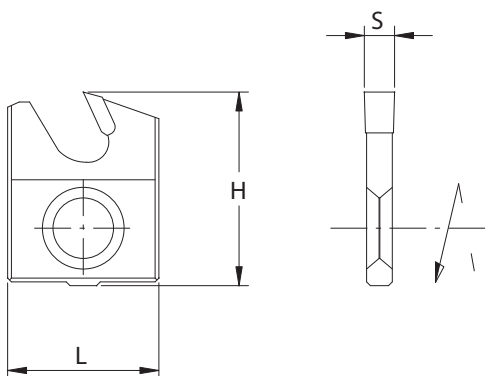

**HW** **MAN** Avanzamento manuale  
Manual feed

Codice Code	L L	H H	S S	Codice Prezzo Price Code
8142.030.025	20	25,6	3	B05
8142.030.035	20	35,6	3	H05
8142.040.025	20	25,6	4	F04
8142.040.035	20	35,6	4	B05
8142.050.025	20	25,6	5	H04
8142.050.035	20	35,6	5	E05
8142.060.025	20	25,6	6	M04
8142.060.035	20	35,6	6	G05
8142.070.025	20	25,6	7	B05
8142.070.035	20	35,6	7	L05
8142.080.025	20	25,6	8	D05
8142.080.035	20	35,6	8	B06

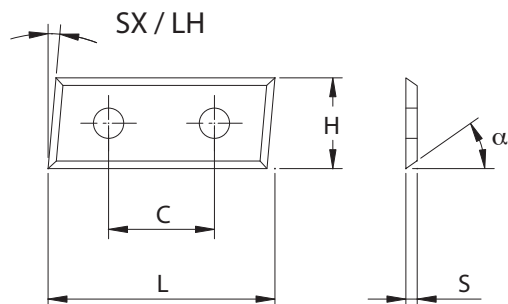

**HC05**

Qualità standard per impiego generale  
Standard quality, for general use

**MG18**

Qualità micrograno, per legni duri  
Micron grade quality, for hardwoods

**HE40**

Qualità speciale per legni teneri  
None cobalt grade for soft woods

DX / RH

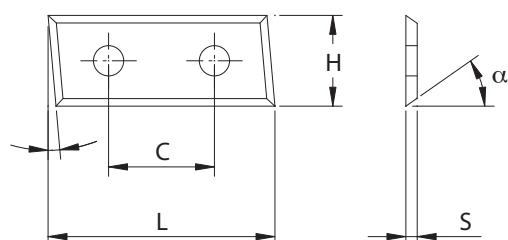

**MG06**

Qualità micrograno, per MDF e truciolare  
Micron grade quality, for MDF and chipboard

**SMG02**

Qualità submicrograno, per MDF e HDF  
Submicron grade quality, for MDF and HDF

**UMG04**

Qualità ultramicrograno, per HDF  
Ultra micron grade quality, for HDF

**Ricambi per Articoli 5065 - 5070 - 5080 - 5085 - 5086**  
**Spare parts for Articles 5065 - 5070 - 5080 - 5085 - 5086**

Codice Dx Rh code	Codice Sx Lh code	L L	H H	S S	C C	$\alpha$ $\alpha$	Qualità Grade	Codice Prezzo Price Code
8145.300.012	8146.300.012	30	12	1,5	14	35°	HC05	EA02
8145.301.012	8146.301.012	30	12	1,5	14	35°	MG06	DA03
8145.302.012	8146.302.012	30	12	1,5	14	35°	UMG04	FA06
8145.303.012	8146.303.012	30	12	1,5	14	35°	SMG02	BA04
8145.304.012	8146.304.012	30	12	1,5	14	45°	MG18	AA03
8145.305.012	8146.305.012	30	12	1,5	14	45°	HE40	CA04
8145.400.012	8146.400.012	40	12	1,5	26	35°	HC05	DA03
8145.401.012	8146.401.012	40	12	1,5	26	35°	MG06	AA04
8145.403.012	8146.403.012	40	12	1,5	26	35°	SMG02	DA05
8145.500.012	8146.500.012	50	12	1,5	26	35°	HC05	DA03
8145.501.012	8146.501.012	50	12	1,5	26	35°	MG06	AA04
8145.502.012	8146.502.012	50	12	1,5	26	35°	UMG04	GA08
8145.503.012	8146.503.012	50	12	1,5	26	35°	SMG02	DA05
8145.504.012	8146.504.012	50	12	1,5	26	45°	MG18	FA04
8145.505.012	8146.505.012	50	12	1,5	26	45°	HE40	HA04
8145.600.012	8146.600.012	60	12	1,5	26	35°	HC05	HA03
8145.601.012	8146.601.012	60	12	1,5	26	35°	MG06	EA06
8145.603.012	8146.603.012	60	12	1,5	26	35°	SMG02	GA09
8145.604.012	8146.604.012	60	12	1,5	26	45°	MG18	DA04
8145.605.012	8146.605.012	60	12	1,5	26	45°	HE40	H03

# 8150 - 8151

## COLTELLI A GETTARE IN HW INTEGRALE SOLID CARBIDE INDEXABLE KNIVES

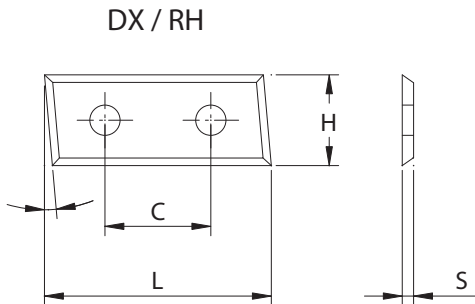
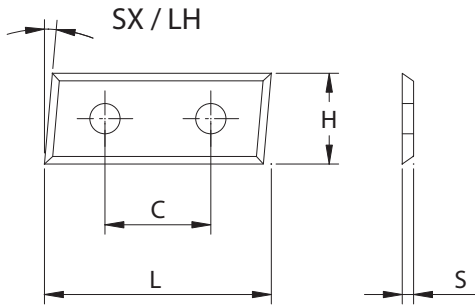

Ricambi per Articoli 5070 - 5080 - 5086  
Spare parts for Articles 5070 - 5080 - 5086

Codice Dx Rh code	Codice Sx Lh code	L L	H H	S S	C C	Qualità Grade	Codice Prezzo Price Code
8150.300.009	8151.300.009	30	9	1,5	14	HC05	EA04
8150.400.009	8151.400.009	40	9	1,5	26	HC05	EA04
8150.500.009	8151.500.009	50	9	1,5	26	HC05	LA04
8150.600.009	8151.600.009	60	9	1,5	26	HC05	LA04

# 8160 - 8161

## COLTELLI A GETTARE IN HW INTEGRALE SOLID CARBIDE INDEXABLE KNIVES

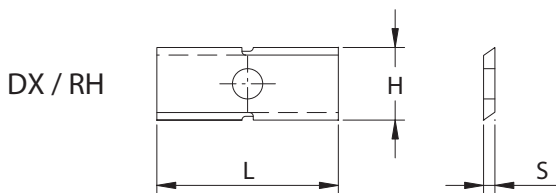
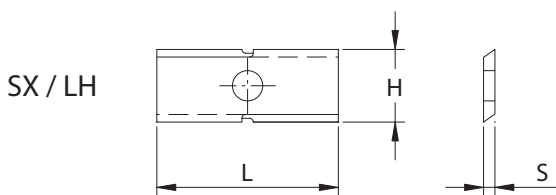

Ricambi per Articolo 5070  
Spare parts for Article 5070

Codice Dx Rh code	Codice Sx Lh code	L L	H H	S S	Qualità Grade	Codice Prezzo Price Code
8160.024.010	8161.024.010	24	10	1,5	HC05	AA06
8160.033.010	8161.033.010	33,6	10	1,5	HC05	GA06

# 8162

## COLTELLI A GETTARE IN HW INTEGRALE SOLID CARBIDE INDEXABLE KNIVES

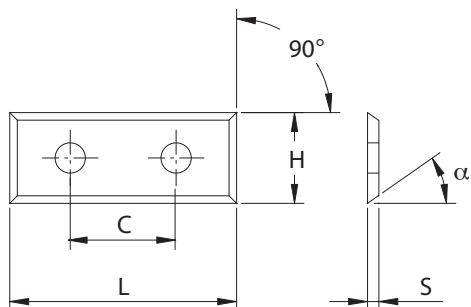

Ricambi per Articoli 5047 - 5048 - 5062  
Spare parts for Articles 5047 - 5048 - 5062

Codice Code	L L	H H	S S	C C	$\alpha$ $\alpha$	Qualità Grade	Codice Prezzo Price Code
8162.300.012	30	12	1,5	14	35°	HC05	EA02
8162.301.012	30	12	1,5	14	35°	MG06	DA03
8162.400.012	40	12	1,5	26	35°	HC05	DA03
8162.401.012	40	12	1,5	26	35°	MG06	FA03
8162.500.012	50	12	1,5	26	35°	HC05	DA03
8162.501.012	50	12	1,5	26	35°	MG06	AA04

# 8163 - 8164

## COLTELLI A GETTARE IN HW INTEGRALE SOLID CARBIDE INDEXABLE KNIVES

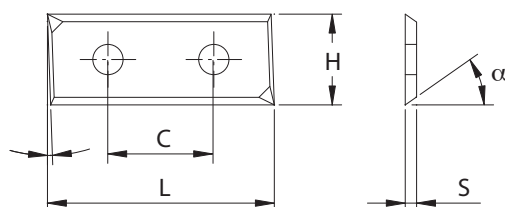

Ricambi per Articolo 5046  
Spare parts for Article 5046

Codice Dx Rh code	Codice Sx Lh code	L L	H H	S S	C C	$\alpha$ $\alpha$	Qualità Grade	Codice Prezzo Price Code
8163.300.012	8164.300.012	30	12	1,5	14	35°	HC05	HA02
8163.301.012	8164.301.012	30	12	1,5	14	35°	MG06	GA03
8163.400.012	8164.400.012	40	12	1,5	26	35°	HC05	GA03
8163.401.012	8164.401.012	40	12	1,5	26	35°	MG06	MA03
8163.500.012	8164.500.012	50	12	1,5	26	35°	HC05	HA03
8163.501.012	8164.501.012	50	12	1,5	26	35°	MG06	FA04

# 8170

## COLTELLI SAGOMATI HW INTEGRALE SOLID HW PROFILE KNIVES

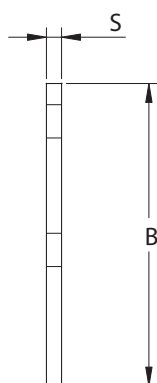
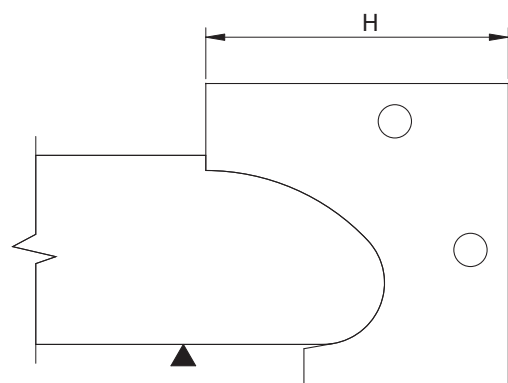

### INFORMAZIONI TECNICHE/TECHNICAL INFORMATION:

Esecuzione con HW integrale micrograno di diverse durezza  
in base al tipo di legno o pannello da lavorare  
*Manufactured with micrograin solid carbide.  
Different hardness depending on the type of wood or panel.*

Codice Code	B B	H H	S S	Codice Prezzo/Price Code					
				6 pcs	12 pcs	24 pcs	36 pcs	60 pcs	96 pcs
8170.020.012	20	12	1,5	C05	G04	A04	L03	H03	F03
8170.025.012	25	12	1,5	G05	A05	E04	C04	A04	M03
8170.015.020	15	20	2	D05	H04	B04	M03	H03	G03
8170.015.025	15	25	2	H05	A05	D04	B04	M03	L03
8170.015.030	15	30	2	A06	D05	G04	D04	C04	A04
8170.020.020	20	20	2	G05	M04	D04	B04	M03	L03
8170.020.025	20	25	2	M05	C05	F04	C04	B04	M03
8170.020.030	20	30	2	C06	F05	L04	F04	D04	C04
8170.020.035	20	35	2	F06	H05	B05	L04	G04	E04
8170.025.020	25	20	2	A06	D05	G04	D04	C04	A04
8170.025.025	25	25	2	B06	E05	H04	E04	D04	B04
8170.025.030	25	30	2	D06	G05	M04	G04	E04	D04
8170.025.035	25	35	2	A07	B06	C05	M04	H04	G04
8170.030.020	30	20	2	B06	D05	H04	E04	D04	B04
8170.030.025	30	25	2	E06	L05	A05	H04	F04	D04
8170.030.030	30	30	2	L06	M05	B05	L04	H04	F04
8170.030.035	30	35	2	E07	E06	F05	D05	B05	L04
8170.030.040	30	40	2	C08	B07	B06	L05	G05	D05
8170.035.020	35	20	2	E06	F05	M04	G04	E04	D04
8170.035.025	35	25	2	H06	M05	C05	M04	L04	G04
8170.035.030	35	30	2	B07	C06	D05	A05	M04	H04
8170.035.035	35	35	2	C08	B07	A06	L05	G05	D05
8170.035.040	35	40	2	A09	L07	G06	E06	B06	L05
8170.040.020	40	20	2	G06	H05	A05	L04	G04	E04
8170.040.025	40	25	2	A07	B06	E05	B05	M04	H04
8170.040.030	40	30	2	D07	E06	F05	C05	A05	L04
8170.040.035	40	35	2	C08	B07	A06	L05	G05	D05
8170.040.040	40	40	2	L09	F08	C07	M06	G06	E06
8170.050.020	50	20	2	C07	D06	E05	B05	M04	H04
8170.050.025	50	25	2	F07	G06	H05	E05	C05	A05
8170.050.030	50	30	2	C08	B07	B06	L05	G05	E05
8170.050.035	50	35	2	F09	C08	M06	H06	E06	B06
8170.050.040	50	40	2	C12	F10	M08	F08	C08	L07
8170.060.020	60	20	2	A08	M06	M05	H05	E05	C05
8170.060.025	60	25	2	F09	C08	A07	G06	E06	B06
8170.060.030	60	30	2	D10	M08	F07	C07	M06	G06
8170.060.035	60	35	2	B11	F09	B08	H07	E07	B07
8170.060.040	60	40	2	D12	G10	A09	G08	D08	M07

# 8175

## COLTELLI SAGOMATI HW INTEGRALE SPECIALI SPECIAL SOLID HW PROFILE KNIVES

### INFORMAZIONI TECNICHE/TECHNICAL INFORMATION:

Esecuzione con HW integrale micrograno di diverse durezza  
in base al tipo di legno o pannello da lavorare  
*Manufactured with micrograin solid carbide.  
Different hardness depending on the type of wood or panel.*

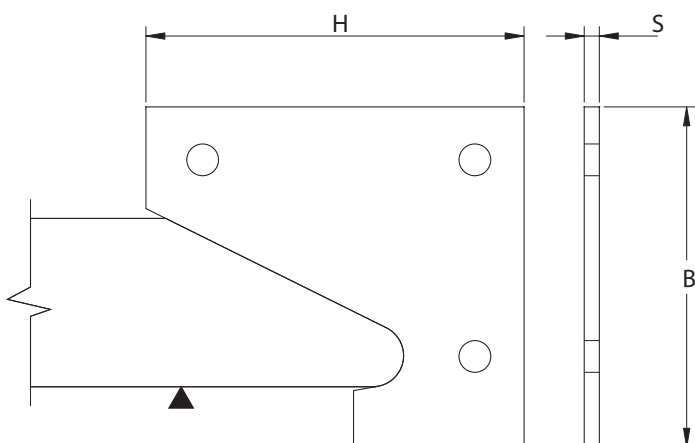

Codice Code	B B	H H	S S	nr. fori nr. of holes	Codice Prezzo/Price Code					
					6 pcs	12 pcs	24 pcs	36 pcs	60 pcs	96 pcs
8175.050.040	50	40	2	3	H12	C11	L09	E09	A09	G08
8175.050.045	50	45	2	3	B14	L12	D11	L10	D10	M09
8175.060.050	60	50	2	3	G14	M13	D12	L11	D11	L10
8175.070.030	70	30	2	2	C12	H10	E09	A09	G08	D08
8175.070.035	70	35	2	2	L12	C11	M09	E09	A09	H08
8175.080.020	80	20	2	2	D11	M09	H08	E08	A08	H07
8175.080.025	80	25	2	2	C12	H10	E09	A09	G08	D08
8175.080.030	80	30	2	2	L12	C11	M09	E09	A09	H08
8175.080.035	80	35	2	2	H13	A12	F10	B10	G09	C09

# 8180

## COLTELLI SAGOMATI HW INTEGRALE SOLID CARBIDE PROFILE KNIVES

### INFORMAZIONI TECNICHE/TECHNICAL INFORMATION:

Ricambi per articolo 5061  
*Spare parts for article 5061*

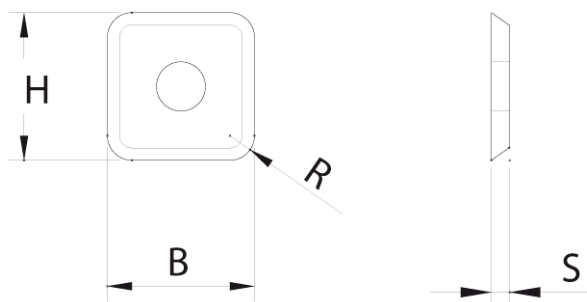

Codice Code	B B	H H	S S	R R	Codice Prezzo/Price Code					
					6 pcs	12 pcs	24 pcs	36 pcs	60 pcs	96 pcs
8180.012.012	12	12	1,5	2	C05	G04	A04	L03	H03	F03

# 8196

## COLTELLI A SAGOMATI IN HW INTEGRALE SOLID CARBIDE PROFILE KNIVES

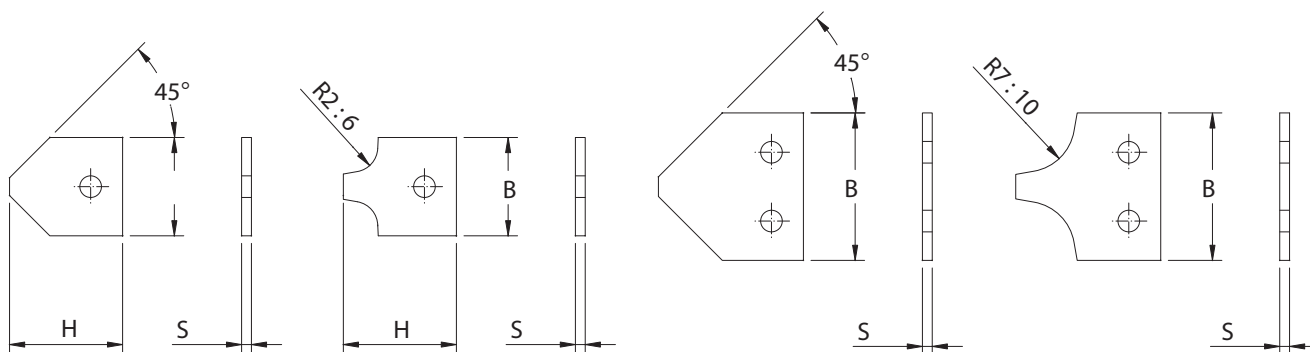

**Ricambi per articolo 2320**  
**Spare parts for article 2320**

Codice Code	B B	H H	S S	R R	Codice Prezzo/Price Code					
					6 pcs	12 pcs	24 pcs	36 pcs	60 pcs	96 pcs
8196.020.045	20	25	2	45°	M05	C05	F04	C04	B04	M03
8196.020.000	20	25	2	2	M05	C05	F04	C04	B04	M03
8196.030.000	20	25	2	3	M05	C05	F04	C04	B04	M03
8196.040.000	20	25	2	4	M05	C05	F04	C04	B04	M03
8196.050.000	20	25	2	5	M05	C05	F04	C04	B04	M03
8196.060.000	20	25	2	6	M05	C05	F04	C04	B04	M03
8196.030.045	30	30	2	45°	L06	M05	B05	L04	H04	F04
8196.070.000	30	30	2	7	L06	M05	B05	L04	H04	F04
8196.080.000	30	30	2	8	L06	M05	B05	L04	H04	F04
8196.090.000	30	30	2	9	L06	M05	B05	L04	H04	F04
8196.100.000	30	30	2	10	L06	M05	B05	L04	H04	F04

# 8200

## COLTELLI A SAGOMATI IN HW INTEGRALE SOLID CARBIDE PROFILE KNIVES

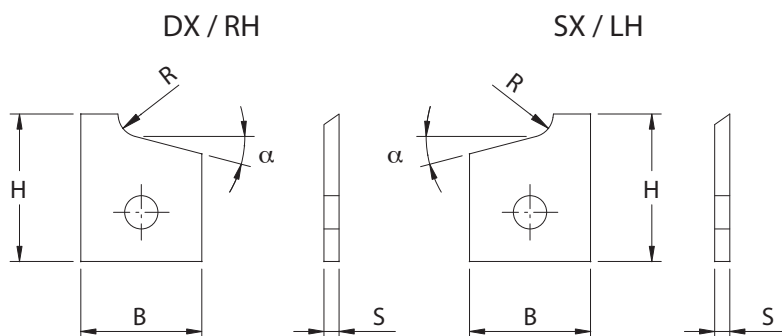

**Ricambi per articolo 2290**  
**Spare parts for article 2290**

Codice Dx Rh Code	Codice Sx Lh Code	B B	H H	S S	R R	α α	Codice Prezzo/Price Code					
							6 pcs	12 pcs	24 pcs	36 pcs	60 pcs	96 pcs
8200.020.001	8200.020.002	16	16,5	2	2	15°	D05	H04	B04	M03	H03	G03
8200.020.003	8200.020.004	16	16,5	2	2	3°	D05	H04	B04	M03	H03	G03
8200.030.001	8200.030.002	16	16,5	2	3	15°	D05	H04	B04	M03	H03	G03
8200.030.003	8200.030.004	16	16,5	2	3	3°	D05	H04	B04	M03	H03	G03

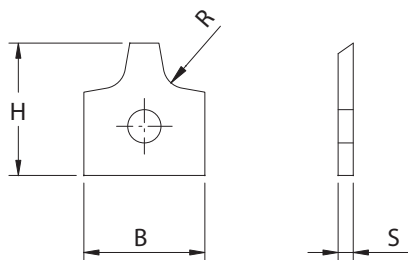

Ricambi per articoli 2245 - 2255 - 2281 - 2285  
Spare parts for articles 2245 - 2255 - 2281 - 2285

Codice Code	B B	H H	S S	R R	Codice Prezzo/Price Code					
					6 pcs	12 pcs	24 pcs	36 pcs	60 pcs	96 pcs
8205.010.000	16	17,5	2	1	D05	H04	B04	M03	H03	G03
8205.015.000	16	17,5	2	1,5	D05	H04	B04	M03	H03	G03
8205.020.000	16	17,5	2	2	D05	H04	B04	M03	H03	G03
8205.025.000	16	17,5	2	2,5	D05	H04	B04	M03	H03	G03
8205.030.000	16	17,5	2	3	D05	H04	B04	M03	H03	G03
8205.040.000	16	17,5	2	4	D05	H04	B04	M03	H03	G03
8205.050.000	16	17,5	2	5	D05	H04	B04	M03	H03	G03
8205.110.000*	16	16,5	2	1	D05	H04	B04	M03	H03	G03
8205.115.000*	16	16,5	2	1,5	D05	H04	B04	M03	H03	G03
8205.120.000*	16	16,5	2	2	D05	H04	B04	M03	H03	G03
8205.125.000*	16	16,5	2	2,5	D05	H04	B04	M03	H03	G03
8205.130.000*	16	16,5	2	3	D05	H04	B04	M03	H03	G03

\* Ricambi per articoli 2245.062.000/2245.062.003

\* Spare parts for articles 2245.062.000/2245.062.003

# 8206

## COLTELLI A SAGOMATI IN HW INTEGRALE PER BORDATRICI SOLID CARBIDE PROFILE KNIVES FOR EDGE BANDERS



SX / LH

DX / RH

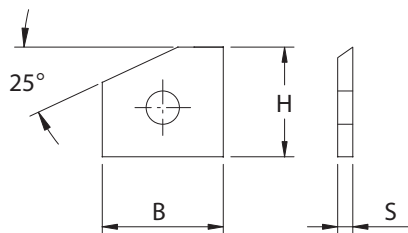
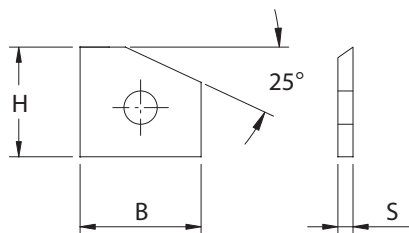

Ricambi per articolo 2280  
Spare parts for article 2280

Codice Dx Rh code	Codice Sx Lh code	B B	H H	S S	Codice Prezzo/Price Code					
					6 pcs	12 pcs	24 pcs	36 pcs	60 pcs	96 pcs
8206.016.001	8206.016.002	16	15,7	2	D05	H04	B04	M03	H03	G03

# 8207

## COLTELLI A SAGOMATI IN HW INTEGRALE PER BORDATRICI SOLID CARBIDE PROFILE KNIVES FOR EDGE BANDERS



SX / LH

DX / RH

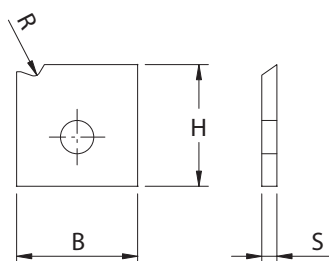
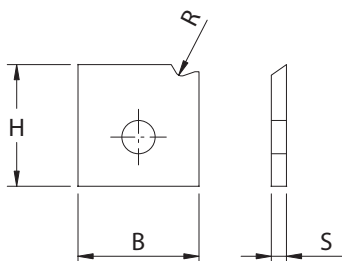

Ricambi per articolo 2275  
Spare parts for article 2275

Codice Dx Rh code	Codice Sx Lh code	B B	H H	S S	R R	Codice Prezzo/Price Code					
						6 pcs	12 pcs	24 pcs	36 pcs	60 pcs	96 pcs
8207.010.001	8207.010.002	16	16	2	1	D05	H04	B04	M03	H03	G03
8207.015.001	8207.015.002	16	16	2	1,5	D05	H04	B04	M03	H03	G03
8207.020.001	8207.020.002	16	16	2	2	D05	H04	B04	M03	H03	G03
8207.030.001	8207.030.002	16	16	2	3	D05	H04	B04	M03	H03	G03

# 8208

## COLTELLI A SAGOMATI IN HW INTEGRALE PER BORDATRICI SOLID CARBIDE PROFILE KNIVES FOR EDGE BANDERS

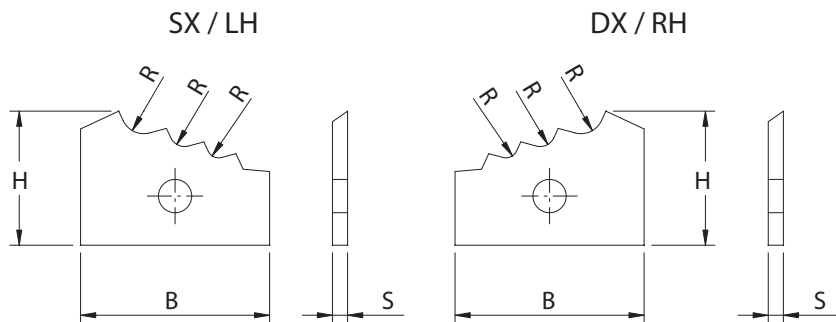

Ricambi per articolo 2276  
Spare parts for article 2276

Codice Dx Rh code	Codice Sx Lh code	B B	H H	S S	R R	Codice Prezzo/Price Code					
						6 pcs	12 pcs	24 pcs	36 pcs	60 pcs	96 pcs
8208.000.001	8208.000.002	25	19	2	1/1,5/2	A06	D05	G04	D04	C04	A04
8208.000.003	8208.000.004	25	19	2	1,5/2/3	A06	D05	G04	D04	C04	A04

# 8210

## COLTELLI A SAGOMATI IN HW INTEGRALE PER BORDATRICI SOLID CARBIDE PROFILE KNIVES FOR EDGE BANDERS

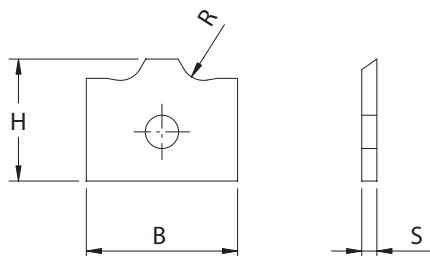

Ricambi per articolo 2266  
Spare parts for article 2266

Codice Code	B B	H H	S S	R R	Codice Prezzo/Price Code					
					6 pcs	12 pcs	24 pcs	36 pcs	60 pcs	96 pcs
8210.010.000	20	16,2	2	1	G05	M04	D04	B04	M03	L03
8210.015.000	20	16,2	2	1,5	G05	M04	D04	B04	M03	L03
8210.020.000	20	16,2	2	2	G05	M04	D04	B04	M03	L03
8210.025.000	20	16,2	2	2,5	G05	M04	D04	B04	M03	L03
8210.030.000	20	16,2	2	3	G05	M04	D04	B04	M03	L03

# 8211

## COLTELLI SAGOMATI IN HM INTEGRALE PER BORDATRICI SOLID CARBIDE PROFILE KNIVES FOR EDGE BANDERS

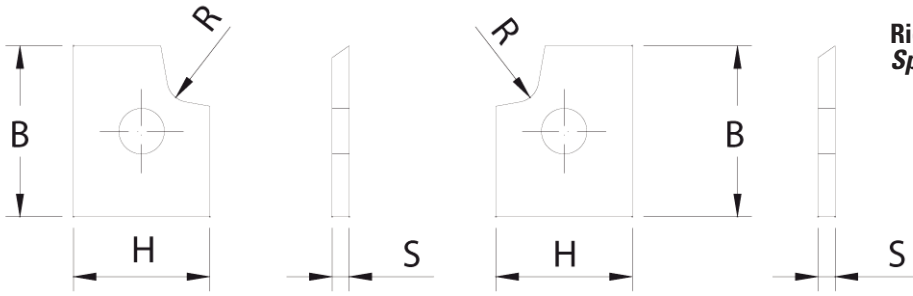

Ricambi per articolo 2298  
Spare parts for article 2298

Codice Dx Rh code	Codice Sx Lh code	B B	H H	S S	R R	Codice Prezzo/Price Code					
						6 pcs	12 pcs	24 pcs	36 pcs	60 pcs	96 pcs
8211.010.001	8211.010.002	15	12	1,5	1	G04	A04	L03	H03	F03	A03
8211.020.001	8211.020.002	15	12	1,5	2	G04	A04	L03	H03	F03	A03
8211.030.001	8211.030.002	15	12	1,5	3	G04	A04	L03	H03	F03	A03

# 8212

## COLTELLI SAGOMATI IN HM INTEGRALE PER BORDATRICI SOLID CARBIDE PROFILE KNIVES FOR EDGE BANDERS

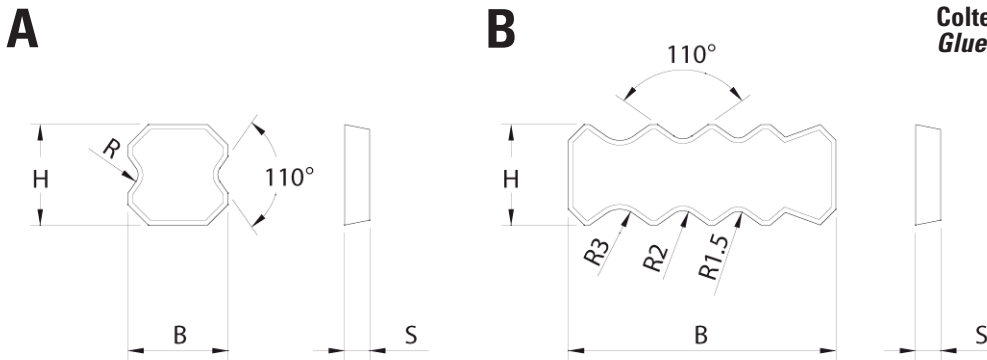

Coltello raschiacolla per bordatrici Biesse  
Glue scraper for Biesse edgebanding machines

Codice Code	B B	H H	S S	R R	Tipo Type	Codice Prezzo Price Code
8212.012.010	12,7	12,7	3,18	1	A	C07
8212.012.015	12,7	12,7	3,18	1,5	A	C07
8212.012.020	12,7	12,7	3,18	2	A	C07
8212.012.030	12,7	12,7	3,18	3	A	C07
8212.034.001	34	12,7	3	1/2/3	B	B12
8212.034.002	34	12,7	3	1,5/2/3	B	B12

# 8213

## COLTELLI SAGOMATI IN HM INTEGRALE PER BORDATRICI SOLID CARBIDE PROFILE KNIVES FOR EDGE BANDERS

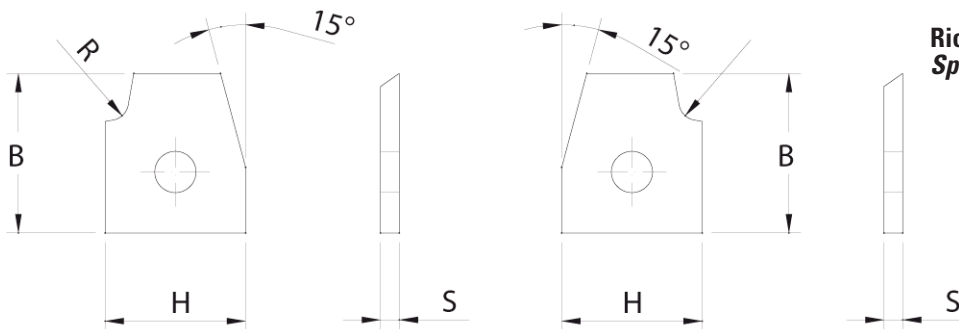

Ricambi per articolo 2289  
Spare parts for article 2289

Codice Dx Rh code	Codice Sx Lh code	B B	H H	S S	R R	Codice Prezzo/Price Code					
						6 pcs	12 pcs	24 pcs	36 pcs	60 pcs	96 pcs
8213.020.001	8213.020.002	15	16	2	2	D05	H04	B04	M03	H03	G03
8213.030.001	8213.030.002	15	16	2	3	D05	H04	B04	M03	H03	G03

# 8230

## COLTELLI SAGOMATI IN HW INTEGRALE PER GIUNZIONI FINGER JOINT SOLID CARBIDE PROFILE KNIVES

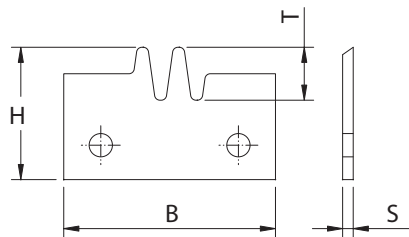

Ricambi per articolo 2470  
Spare parts for article 2470

Codice Code	B B	H H	S S	T T	ND ND	Codice Prezzo/Price Code					
						6 pcs	12 pcs	24 pcs	36 pcs	60 pcs	96 pcs
8230.030.005	30	20	2	5	1	E06	L05	A05	H04	F04	D04
8230.030.010	30	25	2	10	1	L06	M05	B05	L04	H04	F04
8230.030.015	30	30	2	15	1	E07	E06	F05	D05	B05	L04
8230.040.005	40	20	2	5	2	A07	B06	E05	B05	M04	H04
8230.040.010	40	25	2	10	2	D07	E06	F05	C05	A05	L04
8230.040.015	40	30	2	15	2	C08	B07	A06	L05	G05	D05
8230.050.005	50	20	2	5	3	F07	G06	H05	E05	C05	A05
8230.050.010	50	25	2	10	3	C08	B07	B06	L05	G05	E05
8230.050.015	50	30	2	15	3	F09	C08	M06	H06	E06	B06
8230.060.005	60	20	2	5	4	F09	C08	A07	G06	E06	B06
8230.060.010	60	25	2	10	4	D10	M08	F07	C07	M06	G06
8230.060.015	60	30	2	15	4	B11	F09	B08	H07	E07	B07

# 8235

## COLTELLI SAGOMATI IN HW INTEGRALE PER GIUNZIONI FINGER JOINT SOLID CARBIDE PROFILE KNIVES

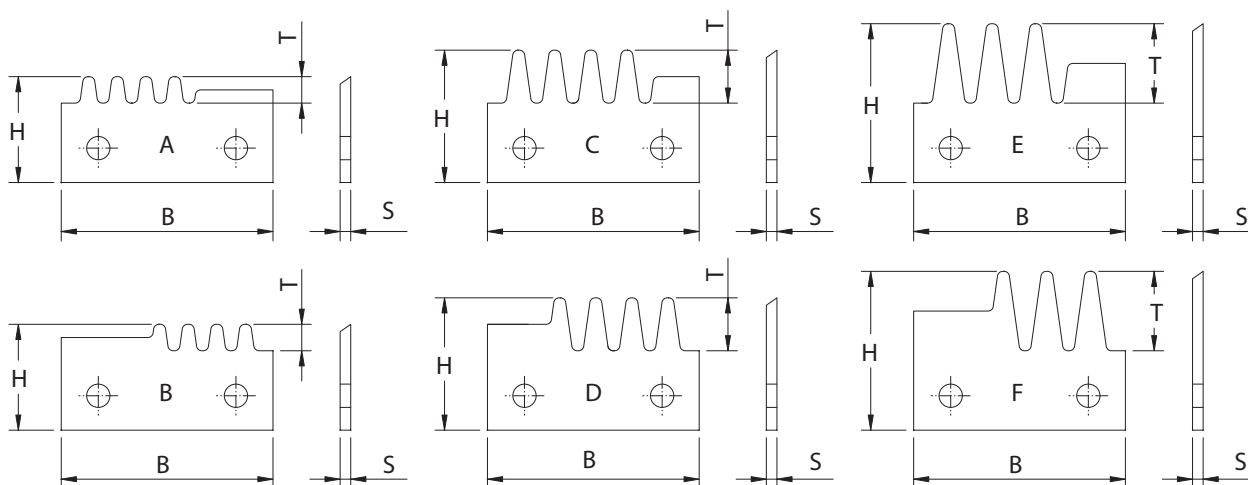

Ricambi per articolo 2475  
Spare parts for article 2475

Codice Code	Tipo Type	B B	H H	S S	T T	ND ND	Codice Prezzo/Price Code					
							6 pcs	12 pcs	24 pcs	36 pcs	60 pcs	96 pcs
8235.040.005	A	40	20	2	5	4	A07	B06	E05	B05	M04	H04
8235.041.005	B	40	20	2	5	4	A07	B06	E05	B05	M04	H04
8235.040.010	C	40	25	2	10	4	D07	E06	F05	C05	A05	L04
8235.041.010	D	40	25	2	10	4	D07	E06	F05	C05	A05	L04
8235.040.015	E	40	30	2	15	3	C08	B07	A06	L05	G05	D05
8235.041.015	F	40	30	2	15	3	C08	B07	A06	L05	G05	D05

# 8240

## COLTELLI SAGOMATI IN HW INTEGRALE PER GIUNZIONI FINGER JOINT SOLID CARBIDE PROFILE KNIVES

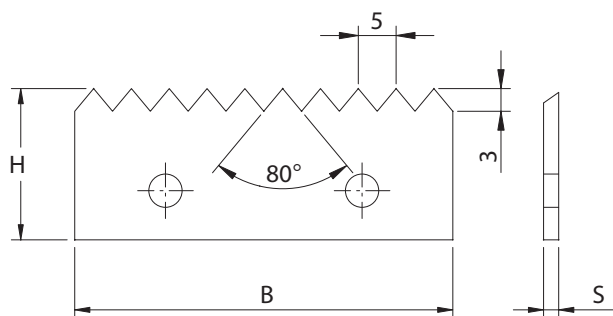

Ricambi per articolo 2480  
Spare parts for article 2480

Codice Code	B B	H H	S S	Codice Prezzo/Price Code					
				6 pcs	12 pcs	24 pcs	36 pcs	60 pcs	96 pcs
8240.050.020	50	20	2	C07	D06	E05	B05	M04	H04
8240.060.020	60	20	2	A08	M06	M05	E05	E05	C05
8240.080.020	80	20	2	D11	M09	H08	E08	A08	H07

# 8245

## COLTELLI SAGOMATI IN HW INTEGRALE SOLID CARBIDE PROFILE KNIVES

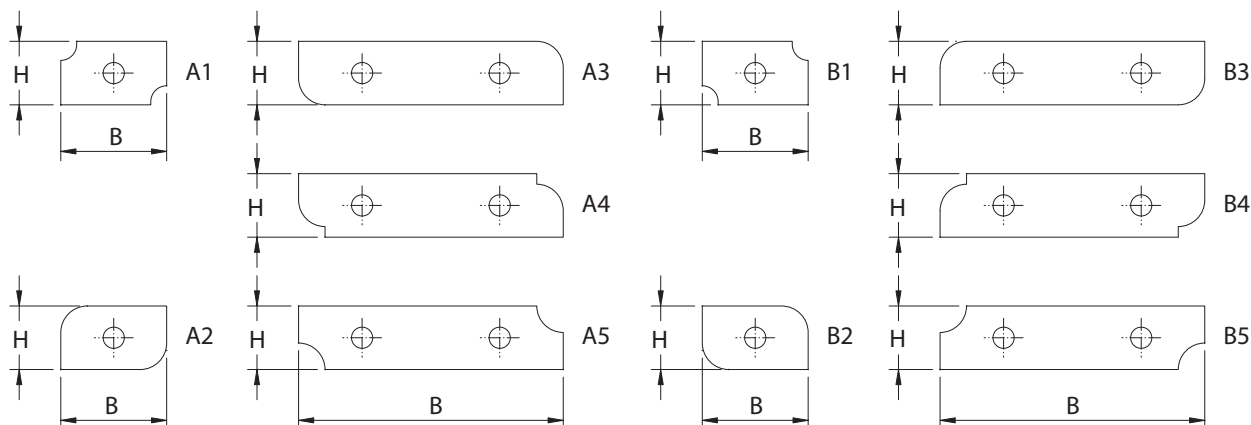

Ricambi per articolo 2515  
Spare parts for article 2515

Codice Code	B B	H H	S S	Tipo Type	Codice Prezzo/Price Code					
					6 pcs	12 pcs	24 pcs	36 pcs	60 pcs	96 pcs
8245.000.001	20	12	1,5	A1	H03	D03	AA09	LA07	MA06	AA06
8245.000.002	20	12	1,5	A2	H03	D03	AA09	LA07	MA06	AA06
8245.000.003	50	12	1,5	A3	B04	H03	D03	A03	GA08	LA07
8245.000.004	50	12	1,5	A4	B04	H03	D03	A03	GA08	LA07
8245.000.005	50	12	1,5	A5	B04	H03	D03	A03	GA08	LA07
8245.000.011	20	12	1,5	B1	H03	D03	AA09	LA07	MA06	AA06
8245.000.012	20	12	1,5	B2	H03	D03	AA09	LA07	MA06	AA06
8245.000.013	50	12	1,5	B3	B04	H03	D03	A03	GA08	LA07
8245.000.014	50	12	1,5	B4	B04	H03	D03	A03	GA08	LA07
8245.000.015	50	12	1,5	B5	B04	H03	D03	A03	GA08	LA07

# 8265

**SUPPORTO SAGOMATO IN ACCIAIO PER TESTE MULTIPROFILO**  
**STEEL PROFILED SUPPORT FOR MULTIPROFILE CUTTER HEADS**

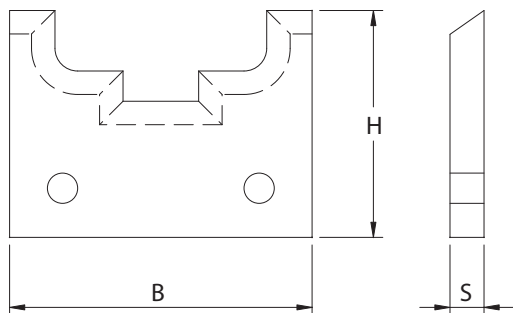

Ricambi per articoli 2430 - 2435 - 2440 - 5025  
Spare parts for article 2430 - 2435 - 2440 - 5025

<b>Codice</b> <i>Code</i>	<b>B</b> <i>B</i>	<b>H</b> <i>H</i>	<b>S</b> <i>S</i>	<b>Cod. Prezzo</b> <i>Price Code</i>
8265.040.030	40	30	4,5	B07
8265.040.035	40	35	4,5	F07
8265.060.030	60	30	4,5	F07
8265.060.035	60	35	4,5	M07

# 8270

**CUNEO DI SERRAGGIO PER TESTE MULTIPROFILO**  
**CLAMPING WEDGE FOR MULTIPROFILE CUTTER HEADS**

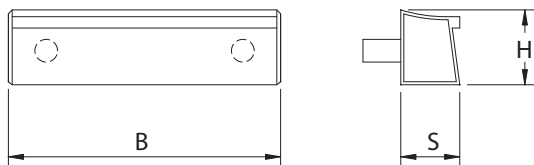

Ricambi per articoli 2430 - 2435 - 2440 - 5025  
Spare parts for article 2430 - 2435 - 2440 - 5025

<b>Codice</b> <i>Code</i>	<b>B</b> <i>B</i>	<b>H</b> <i>H</i>	<b>S</b> <i>S</i>	<b>Cod. Prezzo</b> <i>Price Code</i>
8270.360.000	36	10	8	CA09
8270.560.000	56	10	8	GA09

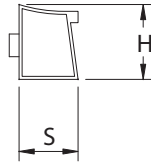
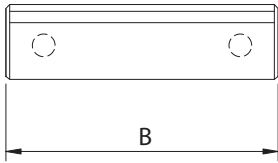
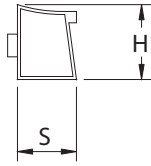
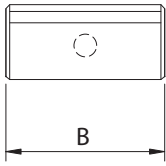

<b>Codice</b> <i>Code</i>	<b>B</b> <i>B</i>	<b>H</b> <i>H</i>	<b>S</b> <i>S</i>	<b>Misura coltello</b> <i>Knife size</i>	<b>Cod. Prezzo</b> <i>Price Code</i>
8280.070.000	7	10	8	7,65 mm / 9,6 mm	HA08
8280.100.000	10	10	8	12 mm	HA08
8280.130.000	13	10	8	15 mm	HA08
8280.160.000	16	10	8	20 mm	HA08
8280.210.000	21	10	8	25 mm	HA08
8280.260.000	26	10	8	30 mm	CA09
8280.360.000	36	10	8	40 mm	CA09
8280.460.000	46	10	8	50 mm	CA09
8280.470.000	47	10	7	50 mm (art. 2205)	GA09
8280.560.000	56	10	8	60 mm	FA09
8280.760.000	76	10	8	80 mm	L03
8280.960.000	96	10	8	100 mm	C04
8281.140.000	14	9	8	16 mm Frese bordatrici/ <i>Edge banding cutters</i>	HA08
8282.160.000	16	13	8	20 mm	FA09
8282.260.000	26	13	8	30 mm	A03
8282.360.000	36	13	8	40 mm	A03
8282.460.000	46	13	8	50 mm	A03
8282.560.000	56	13	8	60 mm	C03

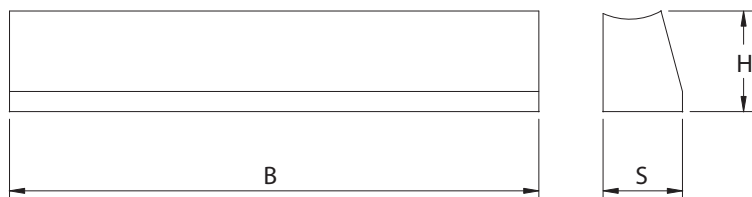
**8283****CUNEO DI SERRAGGIO  
CLAMPING WEDGE**

Ricambi per articoli 2190 - 2195  
Spare parts for articles 2190 - 2195

<b>Codice</b> <i>Code</i>	<b>B</b> <i>B</i>	<b>S</b> <i>S</i>	<b>H</b> <i>H</i>	<b>Cod. Prezzo</b> <i>Price Code</i>
8283.100.000	100	15	19	GA07
8283.120.000	120	15	19	EA08
8283.130.000	130	15	19	CA09
8283.140.000	140	15	19	A03
8283.150.000	150	15	19	F03
8283.170.000	170	15	19	H03
8283.180.000	180	15	19	M03
8283.190.000	190	15	19	B04
8283.220.000	220	15	19	D04
8283.230.000	230	15	19	F04
8283.240.000	240	15	19	H04
8283.250.000	250	15	19	M04

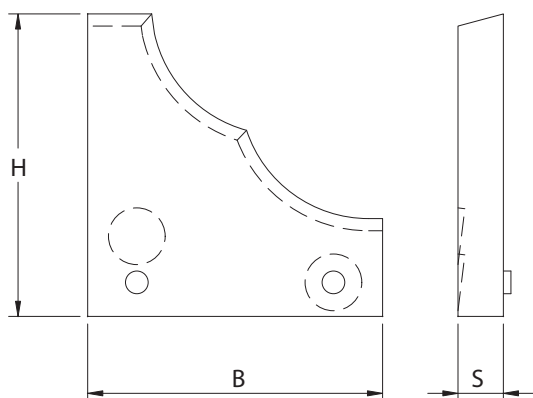
**8284****CUNEO DI SERRAGGIO SAGOMATO  
PROFILED CLAMPING WEDGE**

Ricambi per articoli 2365 - 2370 - 2375  
Spare parts for articles 2365 - 2370 - 2375

<b>Codice</b> <i>Code</i>	<b>B</b> <i>B</i>	<b>S</b> <i>S</i>	<b>H</b> <i>H</i>	<b>Cod. Prezzo</b> <i>Price Code</i>
8240.030.000	30	6	40	M07
8240.040.000	40	6	40	M07
8240.050.000	50	6	40	M07
8240.060.000	60	6	40	M07

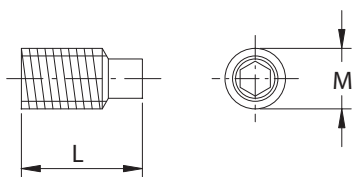

Codice Code	M M	D D	L L	L <sub>1</sub> L <sub>1</sub>	Impiego Use	Cod. Prezzo Price Code
8285.006.000	6	-	14	-	art. 8280.070.000/8281.140.000	AA01
8285.006.001	6	-	12	-	art. 8280.470.000	AA01
8285.008.000	8	-	16	-	art. 8280	AA01
8285.010.000	10	-	20	-	art. 8283	AA01

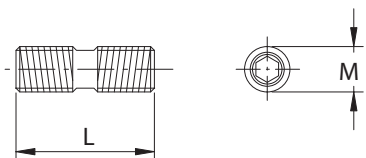

Codice Code	M M	D D	L L	L <sub>1</sub> L <sub>1</sub>	Impiego Use	Cod. Prezzo Price Code
8286.006.000	6	-	18	-	art. 8287.100.000	HA01
8286.010.000	10	-	22	-	art. 8287.150.000	HA01

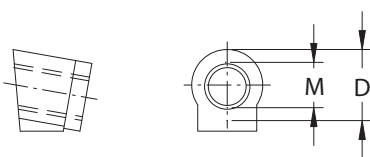

Codice Code	M M	D D	L L	L <sub>1</sub> L <sub>1</sub>	Impiego Use	Cod. Prezzo Price Code
8287.100.000	6	10	-	-	art. 8282.160/460/560	HA02
8287.150.000	10	15	-	-	art. 8282.260/360	HA02

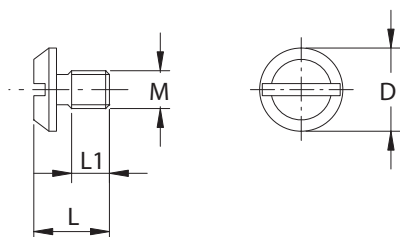

Codice Code	M M	D D	L L	L <sub>1</sub> L <sub>1</sub>	Impiego Use	Cod. Prezzo Price Code
8290.110.000	5	11	10	5	-	HA01
8290.160.000	5	16	11	5	-	HA01

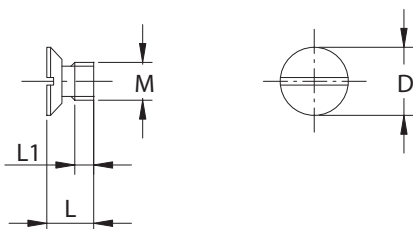

Codice Code	M M	D D	L L	L <sub>1</sub> L <sub>1</sub>	Impiego Use	Cod. Prezzo Price Code
8295.005.000	5	9	8	6	art. 8120.140.002/8120.228.003	AA01

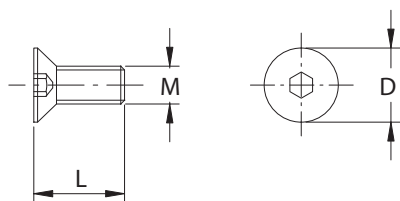

Codice Code	M M	D D	L L	L <sub>1</sub> L <sub>1</sub>	Impiego Use	Cod. Prezzo Price Code
8300.005.000	5	10	12	-	art. 8130	BA01
8300.005.001	5	10	15	-	art. 8131-8132	BA01

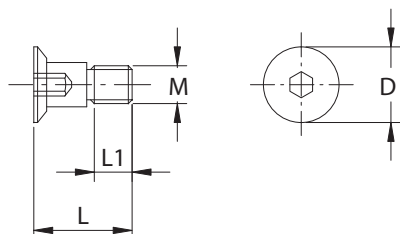

Codice Code	M M	D D	L L	L <sub>1</sub> L <sub>1</sub>	Impiego Use	Cod. Prezzo Price Code
8305.005.000	5	10	13	6	art. 8140-8141-8142	CA01

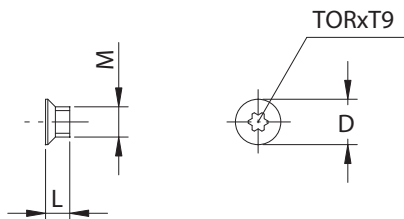

Codice Code	M M	D D	L L	L <sub>1</sub> L <sub>1</sub>	Impiego Use	Cod. Prezzo Price Code
8315.004.001	4	6	3	-	art. 8125.180.019/8120.140.001	CA02
8315.004.002	4	6	5	-	art. 8125.180.029	CA02
8315.004.003	4	6	6,5	-	art. 8125.180.040+8160	CA02

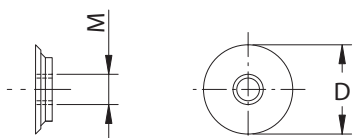

Codice Code	M M	D D	L L	L <sub>1</sub> L <sub>1</sub>	Impiego Use	Cod. Prezzo Price Code
8320.004.000	4	9,9	-	-	art. 8120.140.001+8160	AA03
8320.004.001	4	11,8	-	-	art. 8125	AA03

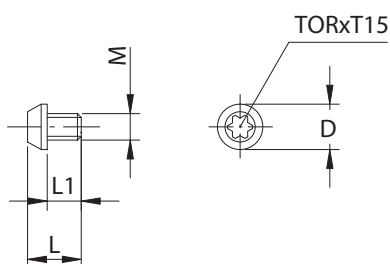

Codice Code	M M	D D	L L	L <sub>1</sub> L <sub>1</sub>	Impiego Use	Cod. Prezzo Price Code
8330.035.002	3,5	6	7	4,5		LA01

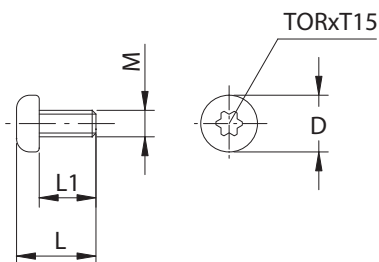

Codice Code	M M	D D	L L	L <sub>1</sub> L <sub>1</sub>	Impiego Use	Cod. Prezzo Price Code
8330.035.003	3,5	7,5	10	7,5		LA01

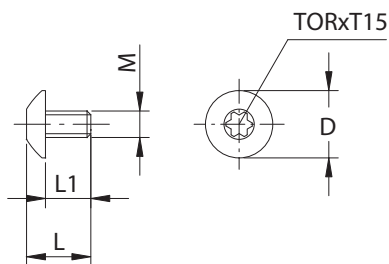

Codice Code	M M	D D	L L	L <sub>1</sub> L <sub>1</sub>	Impiego Use	Cod. Prezzo Price Code
8330.035.004	3,5	9	8,5	6		LA01

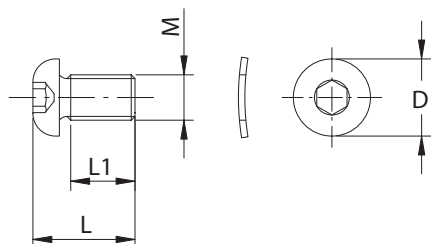

Codice Code	M M	D D	L L	L <sub>1</sub> L <sub>1</sub>	Impiego Use	Cod. Prezzo Price Code
8330.060.000	6	10,5	13	8,5		LA01

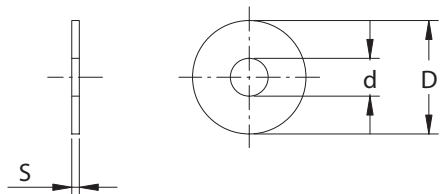

Codice Code	D D	d d	S S	Impiego Use	Cod. Prezzo Price Code
8335.015.001	15	6	0,1	art. 8130/8140	BA01
8335.015.002	15	6	0,3	art. 8130/8140	BA01
8335.015.003	15	6	0,5	art. 8130/8140	BA01
8335.015.004	15	6	1	art. 8130/8140	BA01
8335.015.005	15	6	4	art. 8130/8140	BA01



Codice Code	Cod. Prezzo Price Code
8340.028.001	mm 28x15x14 - Dx/Rh M04
8340.028.002	mm 28x15x14 - Sx/Lh M04

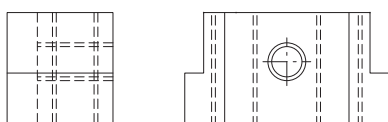

Codice Code	Cod. Prezzo Price Code
8341.028.000	mm 28x15x14 M04

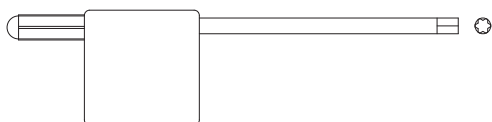

Codice Code	Cod. Prezzo Price Code
8345.009.000	Torx T9 HA03
8345.015.000	Torx T15 HA03

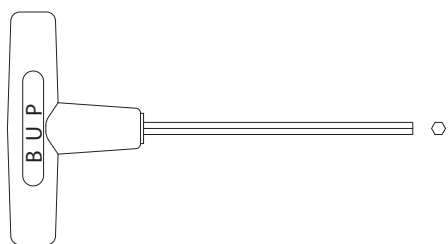

Codice Code	Cod. Prezzo Price Code
8350.025.000	Chiave 2,5 HA03
8350.030.000	Chiave 3 HA03
8350.040.000	Chiave 4 HA03
8350.050.000	Chiave 5 HA03



Codice Code	Cod. Prezzo Price Code
8355.055.000	55 - Ghiera ER 32 M04
8355.065.000	65 - Ghiera ER 40 G05

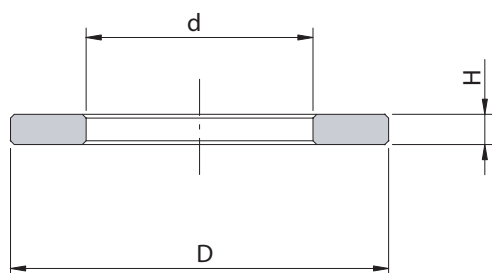

Codice Code	D D	d d	H H	Cod. Prezzo Price Code	Codice Code	D D	d d	H H	Cod.Prezzo Price Code
8370.040.001	40	25+ch	0,1	CA02	8370.060.001	60	40	0,1	CA01
8370.040.002	40	25+ch	0,2	CA02	8370.060.002	60	40	0,2	CA01
8370.040.003	40	25+ch	0,5	CA02	8370.060.003	60	40	0,5	CA01
8370.040.004	40	25+ch	1	CA02	8370.060.004	60	40	1	CA01
8370.040.005	40	25+ch	2	GA05	8370.060.005	60	40	2	BA05
8370.040.006	40	25+ch	3	LA05	8370.060.006	60	40	4	DA05
8370.050.001	50	30	0,1	CA01	8370.060.007	60	40	6	GA05
8370.050.002	50	30	0,2	CA01	8370.060.008	60	40	8	LA05
8370.050.003	50	30	0,5	CA01	8370.060.009	60	40	10	BA06
8370.050.004	50	30	1	CA01	8370.070.001	70	50	0,1	CA01
8370.050.005	50	30	2	GA04	8370.070.002	70	50	0,2	CA01
8370.050.006	50	30	4	LA04	8370.070.003	70	50	0,5	CA01
8370.050.007	50	30	6	BA05	8370.070.004	70	50	1	CA01
8370.050.008	50	30	8	DA05	8370.070.005	70	50	2	LA05
8370.050.009	50	30	10	GA05	8370.070.006	70	50	4	AA06
8370.055.001	55	35	0,1	CA01	8370.070.007	70	50	6	DA06
8370.055.002	55	35	0,2	CA01	8370.070.008	70	50	8	FA06
8370.055.003	55	35	0,5	CA01	8370.070.009	70	50	10	LA06
8370.055.004	55	35	1	CA01	8370.080.001	80	60	0,1	CA01
8370.055.005	55	35	2	LA04	8370.080.002	80	60	0,2	CA01
8370.055.006	55	35	4	AA05	8370.080.003	80	60	0,5	CA01
8370.055.007	55	35	6	DA05	8370.080.004	80	60	1	CA01
8370.055.008	55	35	8	FA05	8370.080.005	80	60	2	LA06
8370.055.009	55	35	10	LA05	8370.080.006	80	60	4	AA07
					8370.080.007	80	60	6	DA07
					8370.080.008	80	60	8	FA07
					8370.080.009	80	60	10	LA07

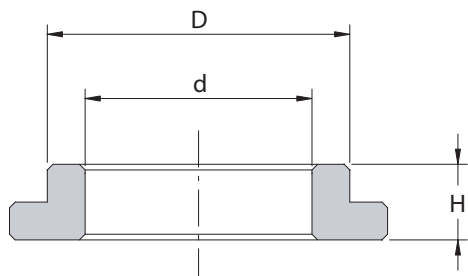
**8375****FLANGE PER RIDUZIONE FORI  
FLANGED SLEEVES**

<b>Codice</b> <i>Code</i>	<b>D</b> <i>D</i>	<b>d</b> <i>d</i>	<b>H</b> <i>H</i>	<b>Cod. Prezzo</b> <i>Price Code</i>
8375.030.020	30	20	10	H03
8375.030.025	30	25	10	H03
8375.035.025	35	25	10	H03
8375.035.030	35	30	10	H03
8375.040.030	40	30	10	M03
8375.040.035	40	35	10	M03
8375.050.030	50	30	10	E04
8375.050.035	50	35	10	E04
8375.050.040	50	40	10	E04
8375.060.030	60	30	10	E04
8375.060.035	60	35	10	E04
8375.060.040	60	40	10	E04
8375.060.050	60	50	10	E04

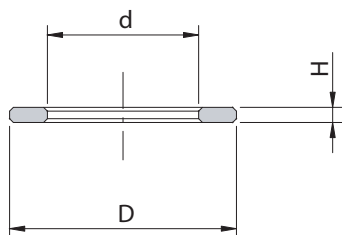
**8380****FLANGE PER RIDUZIONE FORI LAME  
BUSHINGS FOR SAW BLADES**

<b>Codice</b> <i>Code</i>	<b>D</b> <i>D</i>	<b>d</b> <i>d</i>	<b>H</b> <i>H</i>	<b>Cod. Prezzo</b> <i>Price Code</i>
8380.030.001	30	20	2	GA02
8380.030.002	30	25	2	GA02
8380.030.003	30	25,4	2	GA02
8380.032.001	32	30	2	GA02
8380.035.001	35	25	2	GA02
8380.035.002	35	30	2	GA02

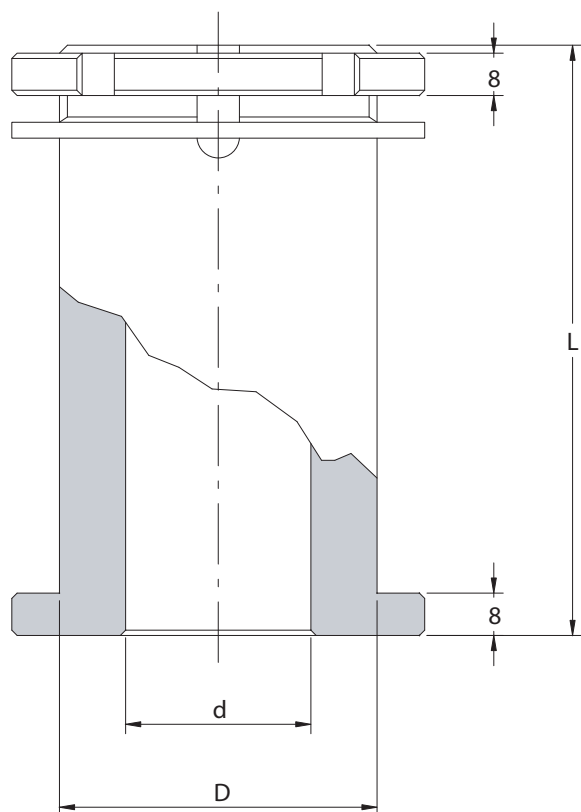
**8385****MOZZO PORTA UTENSILI  
CUTTER SLEEVES**

<b>Codice</b> <i>Code</i>	<b>D</b> <i>D</i>	<b>d</b> <i>d</i>	<b>L</b> <i>L</i>	<b>Cod. Prezzo</b> <i>Price Code</i>
8385.530.095	50	30	95	M15
8385.530.110	50	30	110	M15
8385.530.130	50	30	130	M15
8385.532.095	50	31,75 (1 1/4")	95	M15
8385.532.110	50	31,75 (1 1/4")	110	M15
8385.532.130	50	31,75 (1 1/4")	130	M15
8385.535.095	50	35	95	M15
8385.535.110	50	35	110	M15
8385.535.130	50	35	130	M15
8385.540.095	50	40	95	M15
8385.540.110	50	40	110	M15
8385.540.130	50	40	130	M15
8385.650.060	60	50	60	M15
8385.650.070	60	50	70	M15
8385.650.080	60	50	80	M15
8385.650.090	60	50	90	M15
8385.650.100	60	50	100	M15
8385.650.110	60	50	110	M15
8385.650.120	60	50	120	M15
8385.650.130	60	50	130	M15
8385.650.140	60	50	140	M15

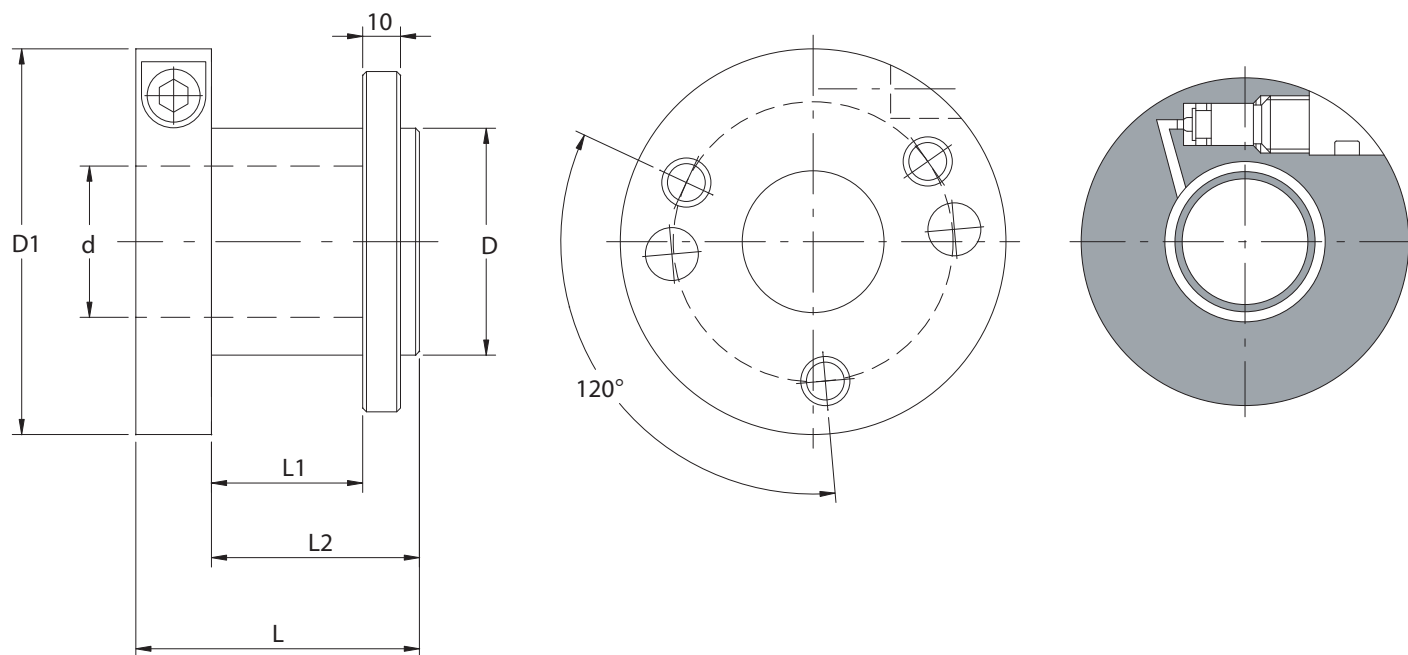

Il mozzo consiste in due elementi d'acciaio tra i quali c'è uno strato di grasso che trasmette la pressione, la quale viene regolata mediante un pistone spinto da una vite.

*The Hub consists of two hardened steel sleeves with an intermediate layer of grease as a pressure medium, which is adjustable with piston pushed by a screw.*

Codice Code	D D	d d	D <sub>1</sub> D <sub>1</sub>	L L	L <sub>1</sub> L <sub>1</sub>	L <sub>2</sub> L <sub>2</sub>	Cod. Prezzo Price Code
8390.535.075	50	35	100	75	40	55	G31
8390.635.075	60	35	102	75	40	55	G31
8390.540.075	50	40	100	75	40	55	G31
8390.640.075	60	40	102	75	40	55	F31
8390.640.095	60	40	108	95	60	75	H31
8390.640.115	60	40	108	115	80	95	M31
8390.650.075	60	50	102	75	40	55	E31
8390.650.095	60	50	108	95	60	75	F31
8390.650.115	60	50	108	115	80	95	H31
8390.538.085	50	38,10 (1 1/2")	100	85	50	65	H31
8390.646.075	60	46,03 (1 13/16")	102	75	40	55	F31
8390.646.095	60	46,03 (1 13/16")	108	95	60	75	L31
8390.646.115	60	46,03 (1 13/16")	108	115	80	95	M31

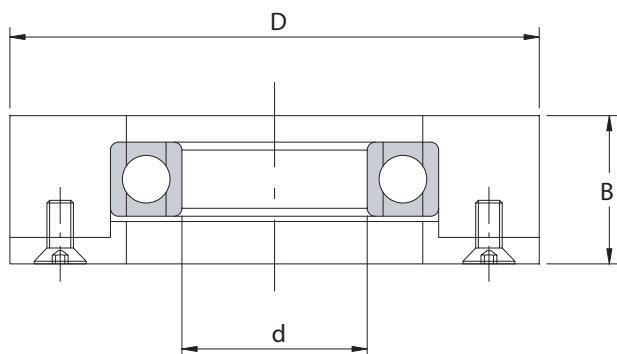

Codice Code	D D	d d	B B	Cod. Prezzo Price Code
8400.100.030	100	30	28	H16
8400.100.032	100	31,75 (1 1/4")	28	H16
8400.100.035	100	35	28	H16
8400.100.040	100	40	28	H16
8400.100.050	100	50	28	H16
8400.110.030	110	30	28	A17
8400.110.032	110	31,75 (1 1/4")	28	A17
8400.110.035	110	35	28	A17
8400.110.040	110	40	28	A17
8400.110.050	110	50	28	A17
8400.120.030	120	30	28	E17
8400.120.032	120	31,75 (1 1/4")	28	E17
8400.120.035	120	35	28	E17
8400.120.040	120	40	28	E17
8400.120.050	120	50	28	E17
8400.125.030	125	30	28	H17
8400.125.032	125	31,75 (1 1/4")	28	H17
8400.125.035	125	35	28	H17
8400.125.040	125	40	28	H17
8400.125.050	125	50	28	H17
8400.140.030	140	30	28	B18
8400.140.032	140	31,75 (1 1/4")	28	B18
8400.140.035	140	35	28	B18
8400.140.040	140	40	28	B18
8400.140.050	140	50	28	B18

### **Prezzi**

Sono quelli riportati nel nostro listino in vigore purchè gli utensili abbiano le caratteristiche riportate nel nostro catalogo (diametro-spessore-foro-n. taglienti etc.). Per misure intermedie ci si dovrà riferire a quella immediatamente superiore.

### **Consegna**

Entro 3 giorni dal ricevimento dell'ordine per utensili pronti a magazzino; entro 20 giorni lavorativi (salvo imprevisti) per utensili speciali su disegno.

### **Spedizioni**

La merce viaggia a rischio e pericolo del committente salvo disposizioni contrarie, per la via da noi ritenuta più vantaggiosa. Le spedizioni si intendono franco ns. fabbrica. L'imballo sarà fatturato al costo.

### **Pagamento**

Il pagamento si intende per contanti al ricevimento della fattura con sconto 3% oppure con tratte autorizzate 30/60 gg. F.M.

### **Ordini**

Non si accettano annullamenti o variazioni trascorsi 3 giorni dal ricevimento dell'ordine. In caso di annullamento la ditta si riserva il diritto di chiedere il rimborso spese sino a quel momento sostenute (materiale e lavorazione). La ditta si riserva inoltre il diritto di modificare le misure che per ragioni tecniche si dovessero ritenere necessarie.

### **Reclami**

Non si accettano trascorsi otto giorni dalla data di consegna.

### **Resi**

Non si accettano trascorsi venti giorni dalla data di spedizione se non preventivamente autorizzati

### **Garanzia**

I nostri utensili sono sottoposti ad accurati controlli e sono garantiti sia qualitativamente che tecnicamente. Nessuna garanzia verrà riconosciuta per utensili manomessi (allargatura fori-affilatura imperfetta) o per utensili impiegati a condizioni non consentite dal tipo di materiale usato per la loro fabbricazione.

Le misure e le illustrazioni sul presente catalogo sono puramente indicative. Ci riserviamo il diritto di apportare le modifiche necessarie per migliorare il prodotto. Eventuali modifiche non danno il diritto a contestazioni. La B.U.P. Utensili si riserva di apportare in qualsiasi momento e senza preavviso le variazioni che riterrà opportune in relazione a quanto contenuto nel catalogo. Tutti i diritti sono riservati e si vieta a chiunque di riprodurre anche parzialmente il presente catalogo senza preventiva autorizzazione scritta dalla Ditta B.U.P. Utensili S.r.l. Studio e Realizzazione grafica a cura dell'ufficio tecnico della B.U.P. Utensili

### **Prices**

*The prices are these quoted in our current list so long as the tools have the characteristics stated in our catalogue (diameter-thickness-bore-number of cutting edges, etc). For intermediate measurements, the immediately higher measurement must be used.*

### **Delivery**

*Within 3 days of receipt of order for tools in stock; within 20 working days (circumstances permitting) for special custom-built tools.*

### **Shipments**

*The goods travel at the buyer's risk and peril subject to provisions to the contrary, by the means we consider most advantageous. Shipmentes are ex our factory. Packing will be billed at cost.*

### **Payment**

*Paument shall be in cash upon receipt of invoice with 3% discount, or by authorized draftas 30/60 days F.M.*

### **Orders**

*No cancellation or changes will be accepted after 3 days from receipt of order. In case of cancellation, the company reserves the right to request reimbursement of expenses sustained to that moment (material and labour). The company also reserves the right to change the measurements for technical reasons if considered necessary.*

### **Claims**

*No claims will be accepted after eight days from the date of delivery.*

### **Returns**

*No returns will be accepted after twenty days from the date of shipment unless authorized in advance.*

### **Guarantee**

*Our tools are subjected to thorough controls and guaranteed for quality and engineering. No guarantee will be recognized for tampering (widening of bores, imperfect sharpening) or for tools used in conditions not permitted by the type of material used for their manufacture.*

*The measurement and illustrations in this catalogue are approximate. We reserve the right to make changes necessary for improving the product. No such can be contested. B.U.P. Utensili reserves the right at time and without notice to make whatever changes it considers appropriate in the contents of the catalogue. All rights are reserved and no one may reproduce this catalogue either entirely or in part without the advance written authorization of B.U.P. Utensili S.r.l.. The technical office B.U.P. Utensili prepared the layout and graphics for this catalogue.*